

**STATE OF UTAH  
DEPARTMENT OF PUBLIC SAFETY**



**OFFICIAL VEHICLE SAFETY INSPECTION MANUAL  
FOR  
PASSENGER VEHICLES AND LIGHT DUTY TRUCKS  
UP TO 26,000 GVWR**

*EFFECTIVE September 27, 2016 – Present*

**UTAH HIGHWAY PATROL  
VEHICLE SAFETY SECTION  
5500 West Amelia Earhart Dr. Suite #360  
Salt Lake City, Utah 84116  
Office: 801-965-4889 Option #1  
Fax: 801-322-1817**

**UTAH INTERACTIVE CUSTOMER SUPPORT LINE: 801-983-0275**

**<http://highwaypatrol.utah.gov/safetyinspection/>**

# TABLE OF CONTENTS

<b>TABLE OF CONTENTS</b>	<b>2</b>
<b>EDUCATIONAL INSTITUTIONS</b>	<b>5</b>
<b>INSPECTOR CERTIFICATION PROCEDURES</b>	<b>6</b>
<b>VEHICLE SAFETY INSPECTION PROCEDURES</b>	<b>7</b>
<b>REJECT VEHICLE PROCEDURES – ON-LINE CERTIFICATES</b>	<b>9</b>
<b>PASSED VEHICLE PROCEDURES – ON-LINE CERTIFICATES</b>	<b>10</b>
<b>BUILDING AND EQUIPMENT REQUIREMENTS</b>	<b>11</b>
<b>SECTION 1 – REGISTRATION</b>	<b>12</b>
A. AGREEMENT AMONG PAPERS	12
B. PLATE MOUNTING	12
<b>SECTION 2 - TIRES AND WHEELS</b>	<b>13</b>
A. TIRE CONDITION	13
B. REGROOVED OR RECUT TIRES	13
C. RESTRICTED MARKINGS	13
D. MISMATCHING	13
E. TIRE WEAR	13
F. WHEELS	13
G. TIRE SIZE, TIRE WIDTH, FENDERS AND MUDFLAPS	14
H. STUDED SNOW TIRES	14
<b>SECTION 3 - STEERING</b>	<b>15</b>
A. LASH OR FREE PLAY	15
B. SIZE	15
C. TRAVEL	15
D. POWER STEERING	15
E. STEERING COLUMN	16
F. IDLER ARMS AND TIE RODS	16
G. RACK AND PINION	16
H. GEARBOX	16
I. PITMAN ARM	17
J. WHEEL BEARINGS	17
K. COTTER PINS	17
<b>SECTION 4 - SUSPENSION</b>	<b>17</b>
A. VEHICLES WITH WEAR INDICATING BALL JOINTS	17
B. VEHICLES WITHOUT WEAR INDICATING BALL JOINTS	18
C. VERTICAL MOVEMENT	18
D. HORIZONTAL MOVEMENT	18
E. SPRINGS	18
F. SWAY BARS / TORSION BARS / TRACKING COMPONENTS	19
G. CONTROL ARMS	19
H. STRUTS	19
I. SHOCK ABSORBERS	19
J. CV AXLE	20
K. U-JOINT	20

<b>SECTION 5 - ALTERED VEHICLES</b>	<b>20</b>
A. <u>LOWERING VEHICLE</u>	<u>20</u>
B. <u>LIFTED VEHICLES</u>	<u>21</u>
<b>SECTION 6 - BRAKES</b>	<b>22</b>
A. <u>PROCEDURE FOR PLATE BRAKE TESTERS</u>	<u>22</u>
B. <u>PROCEDURE FOR VISUAL INSPECTION</u>	<u>23</u>
C. <u>HYDRAULIC SYSTEM</u>	<u>23</u>
D. <u>DUAL HYDRAULIC CIRCUITS</u>	<u>24</u>
E. <u>BRAKES WITH VACUUM ASSIST</u>	<u>24</u>
F. <u>BRAKES WITH HYDRAULIC BOOSTER</u>	<u>25</u>
G. <u>BRAKE DRUMS</u>	<u>25</u>
H. <u>BRAKE ROTORS</u>	<u>26</u>
I. <u>BONDED LINING &amp; PADS</u>	<u>26</u>
J. <u>RIVETED LINING &amp; PADS</u>	<u>27</u>
K. <u>ALL LININGS</u>	<u>27</u>
L. <u>MECHANICAL BRAKE COMPONENTS</u>	<u>27</u>
M. <u>PARKING BRAKE</u>	<u>27</u>
N. <u>ANTI-LOCK BRAKES (ABS SYSTEM)</u>	<u>28</u>
<b>SECTION 7 - LIGHTING</b>	<b>28</b>
A. <u>HEADLAMPS</u>	<u>28</u>
B. <u>BACKUP LIGHTS / LICENSE PLATE LIGHT</u>	<u>29</u>
C. <u>HAZARD WARNING LAMPS</u>	<u>29</u>
D. <u>INTERIOR INDICATOR LAMPS</u>	<u>29</u>
E. <u>PARKING LAMPS</u>	<u>30</u>
F. <u>SIDE MARKER LAMPS</u>	<u>30</u>
G. <u>TAIL LAMP ASSEMBLY</u>	<u>30</u>
H. <u>STOP LAMPS</u>	<u>30</u>
I. <u>TURN SIGNAL OPERATION</u>	<u>32</u>
J. <u>LIGHTING-GENERAL REQUIREMENTS ON ALL VEHICLES</u>	<u>33</u>
<b>SECTION 8 - ELECTRICAL SYSTEM</b>	<b>34</b>
A. <u>HORN</u>	<u>34</u>
B. <u>ELECTRICAL</u>	<u>34</u>
C. <u>ELECTRICAL WIRING</u>	<u>34</u>
D. <u>ELECTRICAL CONNECTIONS</u>	<u>34</u>
E. <u>AUTOMATIC/MANUAL TRANSMISSION STARTING SWITCH</u>	<u>34</u>
F. <u>BATTERY SECUREMENT</u>	<u>34</u>
<b>SECTION 9 - VEHICLE WINDOWS</b>	<b>35</b>
A. <u>WINDSHIELD</u>	<u>35</u>
B. <u>WINDSHIELD DEFROSTER</u>	<u>36</u>
C. <u>WINDSHIELD WIPERS</u>	<u>37</u>
D. <u>WINDSHIELD WASHER</u>	<u>37</u>
E. <u>LEFT/RIGHT FRONT WINDOWS</u>	<u>37</u>
F. <u>WINDOWS BEHIND DRIVER/PASSENGER DOORS</u>	<u>38</u>

<b>SECTION 10 - BODY</b>	<b>39</b>
A. <u>PROTRUDING METAL / PARTS AND ACCESSORIES</u>	<u>39</u>
B. <u>BUMPERS</u>	<u>39</u>
C. <u>FENDERS</u>	<u>40</u>
D. <u>SEATS AND SEAT BELTS</u>	<u>40</u>
E. <u>AIR BAGS</u>	<u>40</u>
F. <u>FLOORBOARDS</u>	<u>41</u>
G. <u>DOORS</u>	<u>41</u>
H. <u>HOOD</u>	<u>41</u>
I. <u>FRAME</u>	<u>42</u>
J. <u>MOTOR MOUNTS / TRANSMISSION MOUNTS / DRIVETRAIN</u>	<u>42</u>
K. <u>EXTERIOR MIRRORS</u>	<u>42</u>
L. <u>INTERIOR MIRROR</u>	<u>43</u>
M. <u>SPEEDOMETER</u>	<u>43</u>
<b>SECTION 11 - EXHAUST SYSTEM</b>	<b>43</b>
A. <u>EXHAUST SYSTEM</u>	<u>43</u>
<b>SECTION 12 – FUEL SYSTEM</b>	<b>44</b>
A. <u>DIESEL / GASOLINE</u>	<u>45</u>
B. <u>LIQUID PROPANE GAS (NFPA-58)</u>	<u>45</u>
C. <u>NATURAL GAS (NFPA-52)</u>	<u>46</u>
<b>SECTION 13- TRAILERS</b>	<b>48</b>
<b>SECTION 14 – OFF HIGHWAY VEHICLES</b>	<b>48</b>
<b>SECTION 15 – CUSTOM VEHICLES (REPLICA VEHICLES)</b>	<b>49</b>
<b>SECTION 16 – LOW-SPEED VEHICLES</b>	<b>50</b>
<b>SECTION 17 - RECONSTRUCTED / SALVAGED MOTOR VEHICLES</b>	<b>51</b>
<b>DEFINITIONS</b>	<b>52</b>

## REGIONAL EDUCATIONAL INSTITUTIONS

### BEAR RIVER REGION #5596

#### **BRIDGERLAND APPLIED TECHNOLOGY CENTER**

Mike Nield, Dept. Head  
Mike Hunter, Instructor  
1301 North 600 West  
Logan, Utah 84321  
**Phone (for students) 435-753-6780**  
**Fax 435-750-3046**

### OGDEN-WEBER REGION #5597

#### **WEBER STATE UNIVERSITY**

Kathleen Rivera, Safety Insp. Certification Coordinator  
John Kelly, Instructor  
Continuing Education – Hurst Center  
1255 East 4100 South Ste. #110  
Ogden, Utah 84408-4006  
**Continuing Education Classes 801-626-6600 / 800-848-7770**  
**Fax 801-626-7686**

### DAVIS-MORGAN REGION #5598

#### **DAVIS ATC**

Ginger Chinn  
550 East 300 South  
Kaysville, Utah 84037-2699  
**New Inspector Classes**  
**Continuing Education Classes 801-593-2100**  
**Fax 801-593-2533**

### WASATCH FRONT SO. REGION #5599

#### **SALT LAKE COMMUNITY COLLEGE / MILLER CAMPUS**

Anita Oleksy, Program Operations Specialist  
Salt Lake Community College  
9750 South 300 West, Bldg. Miller Corporate Partnership  
Center. #215  
Sandy, Utah 84070  
**New Inspector Classes**  
**Phone 801-957-5314**  
**Fax 801-957-5282**

### MOUNTAINLANDS REGION #5600

#### **MOUNTAINLAND ATC**

David Simmons, Coordinator  
John Hyde, Instructor  
Lehi Campus  
2301 West Ashton Blvd.  
Lehi, Utah 84043  
**Student Services 801-753-6282, 801-753-4253**

### CENTRAL REGION #5601

#### **SNOW COLLEGE**

Keith Church, Coordinator  
Bob Gary, Instructor  
200 South 800 West  
Richfield, Utah 84701  
**New Inspector Classes**  
**Phone 435-893-2252**  
**Fax 435-553-0945**

### OGDEN-WEBER TECH COLLEGE #8337

#### **OGDEN WEBER ATC**

Skylar Liston, Instructor  
918 West 2<sup>nd</sup> Street Bldg. 10  
Ogden, Utah 84404  
**Phone 801-612-4130**

Revised 09/06/2016

### SOUTH EAST REGION #5602

#### **UTAH STATE UNIVERSITY, EASTERN CAMPUS**

Stanley Martineau, CEU  
Stanley Wilson, Instructor  
451 East 400 North  
Price, Utah 84501  
**Phone 435-613-5221**  
**Fax 435-613-5801**

### SOUTH EAST REGION #6846

#### **UTAH STATE UNIVERSITY, EASTERN CAMPUS**

Craig Swensen, Instructor  
**Phone 435-678-1386**  
639 West 100 South  
Blanding, Utah 84511  
**Fax 435-678-2220**  
Heidi (San Juan) **435-678-8115**

### SOUTH WEST REGION #5603

#### **SOUTHWEST APPLIED TECHNOLOGY COLLEGE**

Carl Johnson, Coordinator / Instructor  
757 West 800 South  
Cedar City, Utah 84720  
**Classes for New Inspectors & CD Recertification**  
**Phone (for students) 435-586-2899, 435-531-9106**  
**Fax 435-586-2873**

### WEST REGION #5604

#### **DIXIE APPLIED TECHNOLOGY COLLEGE**

Tonya Wall, Coordinator  
Bob Gary, Instructor  
Emergency Response Training Center  
610 Airport Road  
St. George, Utah 84770  
**Phone 435-674-8640**  
**Fax 435-674-0569**

### MOUNTAINLANDS REGION #5600

#### **MOUNTAINLAND ATC**

Matt Zufelt, Coordinator  
Greg Mecham, Instructor  
1210 South Del Monte Rd. (693 West)  
Spanish Fork, Utah 84660  
**Phone 801-753-4115**  
**801-753-4252**

### UINTAH BASIN REGION #5605

#### **UINTAH BASIN ATC**

Lezlee Whiting, Coordinator  
Justin Jorgensen & Tyler Mckee  
450 North 2000 West  
Vernal, Utah 84078  
**New Inspector Classes**  
**Phone 435-725-7100**  
**Fax 435-722-7199**

### UINTAH BASIN REGION #5605

#### **UINTAH BASIN ATC – ROOSEVELT**

Lezlee Whiting, Coordinator  
Bart Miller, Instructor  
1100 E Lagoon St.  
Roosevelt, Utah 84066  
**Phone 435-725-6900**  
**Fax 435-725-6999**

### WASATCH CAMPUS – HEBER #8805

#### **UTAH VALLEY UNIVERSITY, WASATCH CAMPUS**

Mike Walker, Dept. Head  
Mike Bardole, Instructor  
Auto Building  
3111 College Way  
Heber City, Utah 84032  
**Phone 801-863-8012**

## INSPECTOR CERTIFICATION PROCEDURES

- A. Inspectors seeking re-certification of his/her safety inspection authority will be required to obtain re-certification utilizing one of two available options.
1. **Option #1** – Online Safety Inspector re-certification is available at <https://www.utahsafetyinspection.com/>. Only persons certified during the previous year, last 365 days, will be allowed to re-certify utilizing the online certification process. All others, who have allowed their certification to lapse for more than one year (365 days), will be required to attend the full 16 hour Safety Inspection Course offered through any of the Educational Institutions for recertification.
  2. **Option #2** – Attend the entire 16-hour Safety Inspection Course and pass the final test with an 80% or higher score. This course is currently available through the Regional Educational Institutions. Contact them directly for applicable fees.
- B. It has long been a concern of the Utah Highway Patrol that many inspectors have been certified a number of years with no follow-up training provided. This training is being made available in an effort to educate and upgrade inspectors and keep them current on new developments in the Safety Inspection Program. In order to maintain the integrity of the Safety Inspection Program, and to ensure that Utah citizens are receiving a proper safety inspection, this new training requirement has been implemented statewide.
- C. A currently certified inspector may utilize either option #1 or #2 for recertification, no earlier than 60 days prior to the expiration of his/her certification.





## **SAFETY INSPECTION PROCEDURES**

### **A. COMPLETE THE FOLLOWING TASKS BEFORE INSPECTING THE VEHICLE**

1. Collect the appropriate paperwork such as registration, title, and bill of sale.
2. Verify the vehicle identification number (VIN).
3. Record the owner's full name and complete vehicle information.
4. Record the vehicle mileage.
5. Enter the inspection date and inspector number if using a paper inspection certificate.
6. Determine whether the vehicle needs a test drive and the purpose of the test drive.
  - a. If a test drive needs to be conducted off the station's property, the customer shall be informed.

### **B. EXAMINE THE VEHICLE'S INTERIOR BY COMPLETING THE FOLLOWING TASKS**

1. Inspect the windshield, side, and rear windows.
2. Identify mirror requirements and inspect mirrors.
3. Inspect seats and seat belts.
4. Inspect steering wheel/column, including horn and airbags.
5. Inspect brake pedal assembly and emergency brake system.
6. Inspect windshield wipers and washers.
7. Inspect heater and defrost.
8. Inspect dash, including warning indicator lights and speedometer.
9. Inspect doors and door parts.
10. Check the neutral starting switch to determine whether the starter operates with the gear selector only in "park" or "neutral" on vehicles with automatic transmissions.

### **C. EXAMINE THE VEHICLE'S EXTERIOR BY COMPLETING THE FOLLOWING TASKS**

1. Inspect headlight high and low beams, including aiming.
2. Inspect parking lights, tail lights, signal lights, brake lights, marker lights, and reflectors.
3. Inspect for the proper color of lights.
4. Inspect the wheels and lugs, looking for cracks and loose or missing lugs.
5. Inspect tires for wear, damage, and proper inflation.
6. Inspect body of vehicle, including fenders, doors, hood, glass, and bumpers.
7. Inspect for broken glass, parts, and accessories.
8. Inspect window tint with a tint meter, measuring light transmittance on the front side windows and windshield.
  - a. The inspector shall record the tint readings on the certificate using the online inspection program or on the Safety Inspection Certificate if not using the online program.

**D. EXAMINE ITEMS UNDER THE VEHICLE'S HOOD BY COMPLETING THE FOLLOWING TASKS**

1. Inspect belts and hoses.
2. Inspect power steering system.
3. Inspect battery and electrical wiring.
4. Inspect exhaust system.
5. Inspect master cylinder and braking system.
6. Inspect the fuel system.

**E. EXAMINE ITEMS UNDER THE VEHICLE BY COMPLETING THE FOLLOWING TASKS**

1. Inspect steering system, including the wheel bearings, tie rods, rack, and pinion.
2. Inspect suspension components, including the springs and shocks.
3. Inspect exhaust and fuel system components.
4. Inspect body and floor pans.
5. Inspect engine, transmission mounts, and drivetrain.

**F. EXAMINE THE BRAKING SYSTEM BY COMPLETING THE FOLLOWING TASKS**

1. Inspect brake pads/shoes.
2. Inspect brake rotors/drums.
3. Inspect brake components, both hydraulic and mechanical.
4. Inspect brake hoses for fluid leaks.
5. Record brake measurements using the online inspection program or on the Safety Inspection certificate if not using the online inspection program.
6. Issue a rejection inspection certificate on vehicles that fail a plate brake test but have adequate pad and or shoe thickness.
  - a. Record actual brake pad measurement on the rejection inspection certificate.
7. If a visual inspection is performed, remove one front and one rear wheel to inspect brake components.

**G. WHEN INSPECTING A LIFTED VEHICLE, COMPLETE THE FOLLOWING TASKS**

1. Inspect fenders and verify that each one covers the full width of the tire.
2. Inspect mud flaps.
3. Inspect frame height based on the GVWR.
4. Inspect for body lift.
5. Inspect for stacked blocks.
6. Inspect for modification of brake hoses.
7. Inspect headlight aim and vertical height.
8. Inspect altered or modified steering and suspension parts that have been shortened, lengthened, welded.

**H. WHEN INSPECTING LOWERED VEHICLES, COMPLETE THE FOLLOWING TASKS**

1. Inspect that fenders cover full width of tire.
2. Inspect for mud flaps, when required.
3. Inspect for minimum ground clearance.



4. Inspect for removal of original suspension components.
5. Inspect headlight aim and vertical height.
6. Inspect altered or modified steering and suspension parts that have been shortened, lengthened, or welded.

## **REJECT VEHICLE PROCEDURES**



**A. The following procedures apply when a vehicle fails the safety inspection and the inspector is using a paper inspection certificate because the online inspection program is temporarily unavailable.**

1. The inspector shall complete a full vehicle inspection even after a reject item is found.
2. If a vehicle fails an inspection and no repairs are immediately made at that station, then the inspector shall give the customer a rejection inspection certificate.
3. The inspector shall not sign the rejection inspection certificate.
4. A customer with a rejected vehicle has up to 15 calendar days to complete all repairs and return to the same station to verify repairs at no charge.
  - a. Customers may contact the Utah Highway Patrol Safety Inspection Office to request a waiver of additional fees if they exceed 15 days for circumstances beyond their control, such as backordered parts.
5. The inspector shall return the State Tax and Owner copies to the Utah Highway Patrol Safety Inspection Office within 45 days of the inspection date for rejected vehicles that fail to return to the inspecting station.
6. The inspector shall document any item rejected and repaired during an inspection as repaired on the inspection certificate.
7. Any inspector at a station may verify repairs of rejected items.
8. If all rejected items have been repaired, the verifying inspector shall sign the safety inspection certificate.
9. If the verifying inspector is not the original inspector, the verifying inspector shall sign the safety inspection certificate, and enter his or her inspector license number on the safety inspection certificate.

**B. The following procedures apply when a vehicle fails the safety inspection and the inspector is using an online inspection certificate.**

1. If all rejected items have been repaired, the verifying inspector shall sign the safety inspection certificate.
2. If no repairs are made, the inspector shall print the rejection inspection certification and give it to the customer.
3. The inspector shall not sign a rejection inspection certificate.
4. A customer with a rejected vehicle has up to 15 calendar days to complete all repairs and return to any station that conducts online inspections to verify repairs at no charge.

- a. Customers may contact the Utah Highway Patrol Safety Inspection Office to request a waiver of additional fees if they exceed 15 days for circumstances beyond their control, such as back ordered parts.
- 5. The inspector shall document any item rejected and repaired during an inspection as repaired on the inspection certificate.
- 6. Any inspector at a facility may certify repairs made to rejected items. No additional charges may be added.

**PASSED VEHICLE PROCEDURES**



**A. The following procedures apply when a vehicle passes the safety inspection and the inspector is using a paper inspection certificate because the online inspection program is temporarily unavailable.**

- 1. The inspector performing the inspection shall sign the vehicle inspection certificate.
- 2. The customer shall be given the State Tax and Owner copies of the inspection certificate.

**B. The following procedures apply when a vehicle passes the safety inspection and the inspector is using an online inspection certificate.**

- 1. The inspector shall print the vehicle inspection certificate and give it to the customer.
- 2. The inspector performing the inspection shall sign the printed inspection certificate prior to giving it to the customer.

\$7.00	Motorcycles and ATV's.
\$15.00	Passenger vehicles, trucks, full size ATV's (up to 26,000 lbs. GVWR or less).
\$15.00	Trucks and buses over 26,000 lbs. GVWR or any trailer.
\$20.00	Any vehicle that requires the disassembly of a front hub or removal of a rear axle for inspection.

**INSPECTION REPORT PROCEDURE (PAPER INSPECTION CERTIFICATE ONLY)**

**A. All inspection certificates are issued through the online inspection program, unless the program is temporarily unavailable. The following inspection report procedures apply when the online inspection program is temporarily unavailable and the inspector is using a paper inspection certificate.**

- 1. The report forms shall include the following information.
  - a. Date the inspection was completed.
  - b. Owner's name.
  - c. Year and make of the vehicle.

- d. Vehicle identification number (VIN).
  - e. Appropriate notation in any of the repair columns.
  - f. Total cost of the repair, including the inspection fee.
  - g. Inspection certificate number.
2. Inspection certificate numbers of paper books shall be listed in numerical order starting with the lowest number and listed in groups of 25.
  3. A separate report form shall be used for the inspection certificates and for the stickers.
  4. Duplicate inspection certificates shall be noted as “duplicate” on the report form.
  5. Lost or stolen inspection certificates shall be listed as “Lost or stolen” on the report form.
  6. Inspection certificates and stickers rendered unusable through mishap shall be recorded as “voided” on the report form and inspection certificates and stickers shall be returned to the Vehicle Safety Inspection office.
  7. Rejected vehicles that have not returned within 15 days to the original station shall be listed in the same order and the words “rejected,” printed on the same line.
  8. Failure to submit the required reports may result in suspension or revocation of a permit.
  9. The inspector shall return the State Tax and Owner copies to the division within 45 days of the original inspection date for rejected vehicles that fail to return for re-inspection.
  10. Enter the information from a paper inspection certificate to the online inspection program within 72 hours after the program becomes available again.

## **BUILDING AND EQUIPMENT REQUIREMENTS**



### **A. Passenger car and light truck inspection tool requirements.**

1. Hoist and/or heavy duty jack with jack stands.
  - a. All new stations after January 1, 2009 are required to have a hoist capable of lifting all four tires simultaneously off the ground.
2. 2 piece light meter.
3. Hand tools (wrenches, screwdrivers, ratchets, etc.).
4. Dial indicator.
  - a. For measuring ball joint and suspension component tolerances.
5. Tire tread depth gauge.
6. Current Safety Inspection Manual.
  - a. May be a hard copy or a downloaded copy to a computer at the station.
7. Tire pressure gauge.
8. Tape measure.
9. Brake gauges.
  - a. Bonded.
  - b. Riveted.

- i. Riveted brake lining gauge can be used for the tire tread depth gauge.
- c. Disc pad.
- d. Rotor.
- e. Drum.

## **SECTION 1 – REGISTRATION**



### **A. When reviewing vehicle registration papers, the inspector shall:**

1. Check the vehicle registration certificate, identification number on vehicle, license plates, and vehicle description for agreement.
2. Enter the manufacturer's Vehicle Identification Number and license plate number into the online program or record on the safety inspection certificate if not using the online program.
  - a. **Advise** when:
    - i. Paperwork disagreements are accidental or clerical in nature.
  - b. **Reject** when:
    - i. The registration certificate, vehicle identification number, license plate, and vehicle description are not in agreement.
    - ii. The Vehicle Identification Number is missing or obscured.
3. Verify the Vehicle Identification Number on all inspections.



### **B. The inspector shall examine the vehicle's license plates and comply with the following requirements:**

1. If the vehicle is registered, verify the license plates are secured mounted and clearly visible.
  - a. **Advise** when:
    - i. License plates are not securely fastened to the rear of the vehicle, in a horizontal position, not less than 12 inches from the ground when measured from the bottom of the license plate.
    - ii. License plates are not located in a clearly visible position.
    - iii. License plates covered with foreign material or otherwise not clearly legible.

NOTE: Utah Law requires two plates be mounted on every vehicle. Except "apportioned" plates, which need only one plate.

## SECTION 2 – TIRES AND WHEELS



### **A. When examining the tires and wheels, the inspector shall:**

1. Check tires for cuts, cracks, or sidewall plugs.
  - a. **Advise** when:
    - i. A tire has weather cracks, but no cords showing.
  - b. **Reject** when:
    - i. A tire has sidewall plugs, cuts, or cracks deep enough to expose cords.
2. Check tires for indication of tread separations.
  - a. **Reject** when:
    - i. Tire integrity has been compromised due to visible bumps, bulges, or tire separation.
3. Check tire pressure for proper inflation with tire pressure gauge.
  - a. **Reject** when:
    - i. A tire is flat, has a noticeable air leak, or is inflated to less than half (50%) of the vehicle manufacturer's recommended tire pressure.
4. Check tires for re-grooving or re-cutting.
  - a. **Reject** when:
    - i. A tire is re-grooved and is not identifiable as re-groovable.
5. Check tires for "restricted usage only" markings.
  - a. **Reject** when:
    - i. A tire is marked "for farm use only", "off-highway use only", "for racing only", "for trailers only", or other non-highway use.
6. Check tires for the same size and same type of construction.
  - a. All tires on the same axle must be of the same size and construction, but mismatched tread design is allowed.
  - b. **Reject** when:
    - i. Tires on the same axle are not the same size or construction.
7. Check tire wear.
  - a. **Advise** when:
    - i. Tread wear bars are touching the road surface.
  - b. **Reject** when:
    - i. The tread depth is less than 2/32 inch when measured in any two adjacent major tread grooves at three equally spaced intervals around the circumference of the tire. Tread depth measurement shall not use a tread wear bar.
    - ii. Secondary rubber is exposed in the tread or sidewall area.
8. Check wheels for damage and proper mounting.
  - a. **Reject** when:
    - i. Wheel bolts, nuts, studs, or lugs are loose, missing, or not properly fastened.
    - ii. Wheels are bent, cracked, re-welded, or have elongated bolt holes.



- iii. Spacers are used to increase the wheel track width.
- iv. Bead lock wheels are installed that do not meet the SAE J2530 Aftermarket Wheel Performance Requirements and Test Procedures. Bead lock wheels that meet this standard will be stamped with an SAE marking indicating the wheel meets the standard.



ADAPTER (Pass)



SPACER (Reject)

NOTE: A wheel adaptor changes the bolt pattern of a vehicle's hub and moves the wheel out allowing the use of custom wheel's for most cars. Wheel adapters are not spacers.

- 9. Check vehicle tires for proper size and weight load ratings.
- 10. Check that fenders and mudflaps are in place when required.

a. **Advise** when:

- i. Fenders or fender extenders do not cover the full width of a tire.
- ii. Rear tires do not have the top 50% of the tire covered by mudflaps, fenders, or the vehicle body construction when required.
- iii. Rear mudflaps are not directly aligned with the tire and at least as wide as the tire when required.



b. **Reject** when:

- i. Tires do not meet the proper load rating for the vehicles actual weight (Gross Vehicle Weight).
- ii. Tires are mounted on wheels that are not within tire manufacturer specifications.
- iii. Tire tread is not fully covered by existing fenders or fender extenders.
- iv. Tires make contact with any other vehicle parts or accessories.
- v. Fender flares or mud flaps are not made of durable material.
- vi. Fender flares or mud flaps are not secured properly.

- 11. Check for studded snow tires.

a. **Advise** when:

- i. Studded snow tires are mounted on a vehicle between April 1 and October 14 of any year.

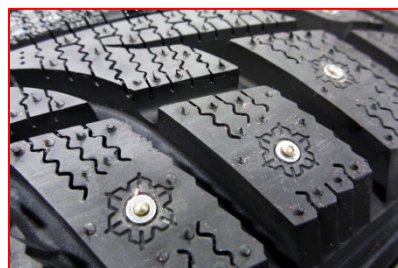

## SECTION 3 – STEERING

NOTE: right-handed steering systems must be OEM to pass safety inspection. Waivers will not be granted for after-market conversions.

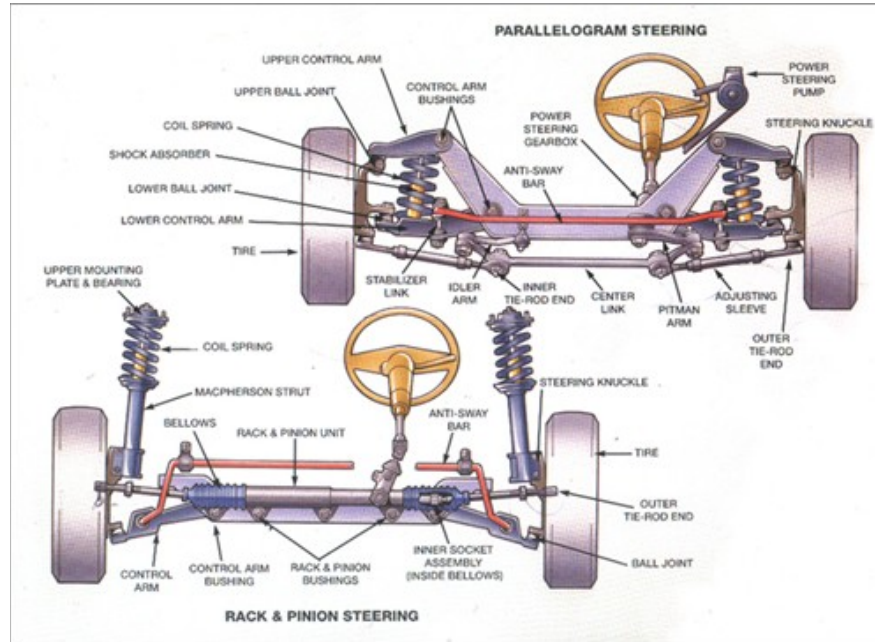

A. The steering system must be inspected to determine if excessive wear or maladjustment of the linkage or steering gear exist. Vehicle must be on a smooth, dry, level surface. On vehicles equipped with power steering, the engine must be running and the fluid level, belt tension and condition must be adequate before testing.

B. When inspecting the vehicle's steering system, the inspector shall:

1. Measure lash at steering wheel.
  - a. **Reject** when:
    - i. Steering wheel movement exceeds:
      1. 2 inches for power steering.
      2. 3 inches for manual steering.
      3. 0.4 of an inch for rack and pinion.
2. Check the size of steering wheel.
  - a. **Reject** when:
    - i. Steering wheel is less than 13 inches in outside diameter or is not of full circular construction.
3. Check for binding or jamming conditions by turning the steering wheel through a full right and left turn without the brake being applied.
  - a. **Reject** when:
    - i. Steering is incapable of being turned fully from right to left.
    - ii. One wheel turns before the opposite wheel.
4. Check the condition and tension of steering belts if the vehicle is equipped with power steering.
  - a. **Advise** when:





- i. Steering belts are cracked or are not properly adjusted.
  - b. **Reject** when:
    - i. Steering belts are frayed or torn.
- 5. Check the condition of the power steering system, hoses, hose connections, cylinders, and valves.
  - a. **Reject** when:
    - i. Hoses or hose connections have a dripping leak.
    - ii. Cylinders or valves have a dripping leak.
- 6. Check the condition of the pump and check for secure mounting and proper fluid level in the reservoir.
  - a. **Reject** when:
    - i. Pump mounting parts are loose or broken.
    - ii. The system is inoperative.
    - iii. Reservoirs have a dripping leak.
    - iv. The fluid level is below minimum fluid level indicators.
- 7. Check for separation of the shear capsule from bracket and general looseness of steering wheel and column.
  - a. **Reject** when:
    - i. The shear capsule is separated from bracket.
    - ii. The wheel and column can be moved as a unit.
- 8. Check movement on tilt steering wheels.
  - a. **Reject** when:
    - i. Adjustable steering wheel cannot be secured in all positions
    - ii. Steering column has 3/4 inch or more movement at the center of the steering wheel when it is in locked in position.
    - iii. Steering wheel and column is on the right side of the vehicle that is not OEM or the owner does not possess a valid waiver from the safety inspection office.
- 9. Check the idler arms and tie rod ends for looseness in excess of OEM specifications.
  - a. **Advise** when:
    - i. Tie rod grease seals are cut, torn, or otherwise damaged to the extent that lubricant will not be retained.
  - b. **Reject** when:
    - i. There is looseness in the tie rod ends or idler arm in excess of OEM specifications.
    - ii. The tie rod is bent, causing the vehicle to be out of alignment.
- 10. Conduct a thorough inspection of the complete rack and pinion system.
  - a. **Reject** when:
    - i. There is any looseness in excess of OEM specifications.
    - ii. There is any looseness in the tie rod ends in excess of OEM specifications.
    - iii. There is a dripping leak.
- 11. Check the steering gear box for proper function.
  - a. **Advise** when:
    - i. Gearbox on vehicle with manual steering has a dripping leak.
  - b. **Reject** when:
    - i. There is looseness at the frame or mounting.





- ii. There are any cracks.
- iii. Any mounting brackets are cracked.
- iv. Any fasteners are missing.
- v. There is a dripping leak.
- vi. Any welded repair is present.

12. Check the pitman arm.

- a. **Reject** when:
  - i. The gearbox output shaft has movement inside the pitman arm.
  - ii. Any welded repair is present.

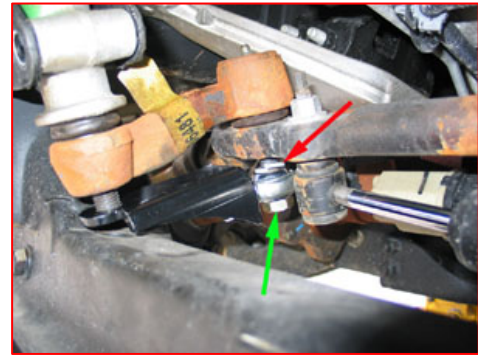

13. Check all wheel bearings for looseness with the vehicle lifted, by grasping the top and bottom of the tire and rocking it in and out.

- a. **Reject** when:
  - i. Issue a rejection inspection certificate when any bearing has movement of more than 1/8 inch when measured at the outer circumference of the tire.

14. Check all the steering components and axle nuts for required cotter pins.

- a. **Reject** when:
  - i. Any cotter pins are missing or ineffective.

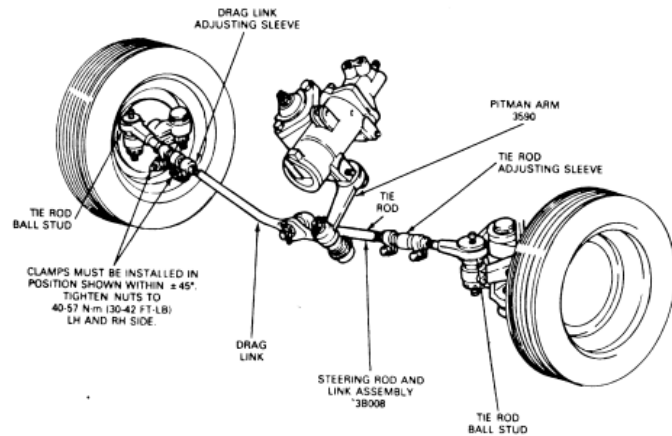

## SECTION 4 – SUSPENSION



**A. When inspecting the vehicle's suspension, the inspector shall:**

1. Support vehicle with the ball joints loaded and wheels straight ahead. Wipe the grease fitting and check to ensure the surface is free of dirt and grease. Determine if checking surface extends beyond the surface of the ball joint cover.
  - a. **Advise** when:



- i. Any ball joint seal is cut, torn, or otherwise damaged to the extent it will not retain lubricant.
- b. **Reject** when:
  - i. A ball joint wear indicator is flush or inside the cover surface.
  - ii. Ball joint movement is in excess of manufacturer's specifications.

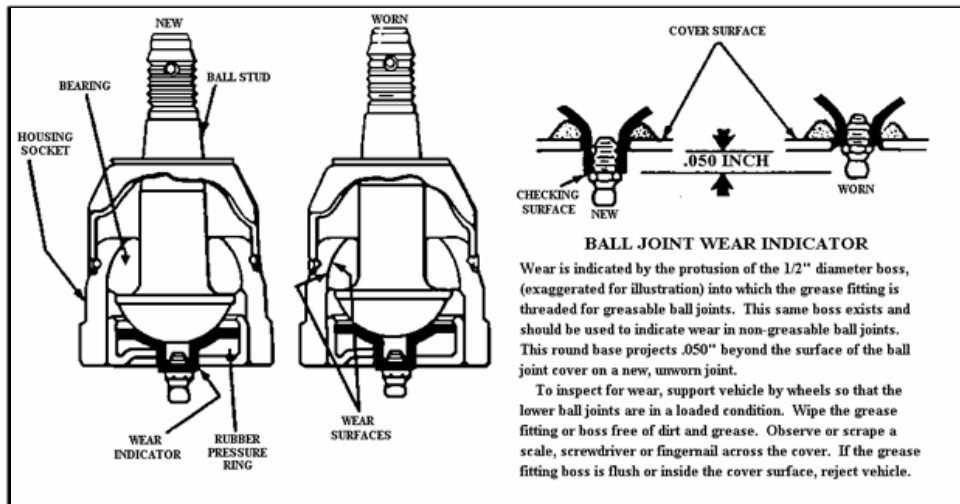

- 2. If the vehicle does not have a wear indicating ball joint, unload the ball joints by raising the vehicle and checking the ball joint seals.

- a. **Advise** when:
  - i. Any ball joint seals is cut, torn, or otherwise damaged to the extent that it will not retain lubricant.



- b. **Reject** when:
  - i. The ball joint movement is in excess of manufacturer's specifications.

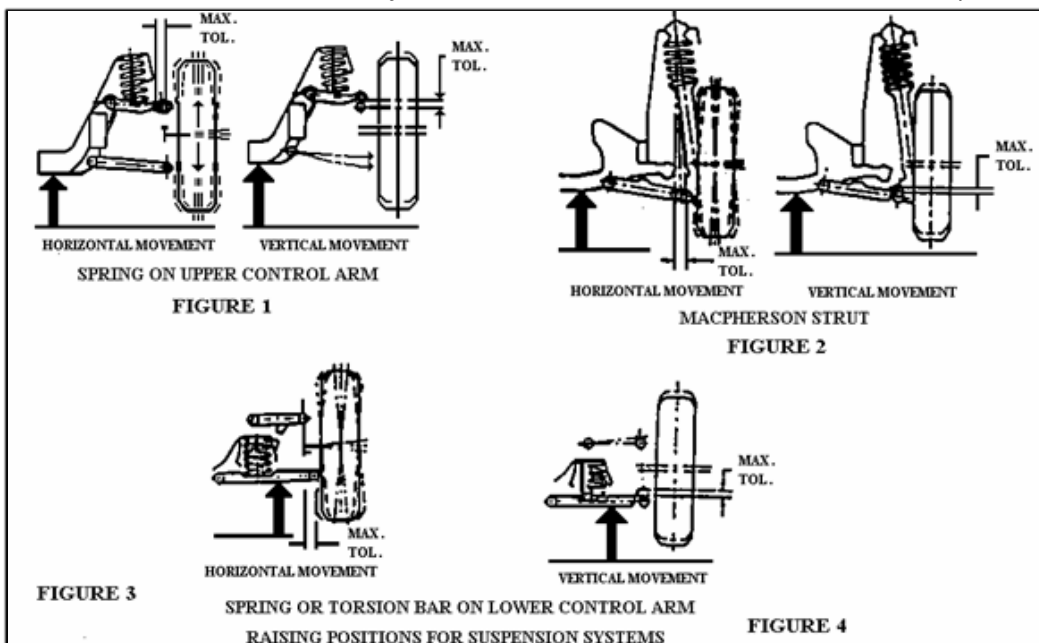

3. Position a pry bar under the front tire and with a lifting motion, sufficient to overcome the weight of the wheel assembly only, and move the wheel up and down.
  - a. **Reject** when:
    - i. The ball joint movement is in excess of manufacturer's specifications.
4. Grasp the tire and wheel assembly at the top and bottom and move the assembly in and out to detect looseness.
  - a. **Reject** when:
    - i. Movement is in excess of manufacturer's specifications.
5. Visually inspect for broken or damaged leaf springs.
  - a. **Reject** when:
    - i. Springs are missing, cracked, broken, disconnected, or cut.
    - ii. Springs are sagging and allow the body to come in contact with the tires.
6. Check the spring shackles.
  - a. **Reject** when:
    - i. Shackles are damaged or loose.
    - ii. Shackles have been modified and don't meet OEM specifications.
7. Check the U-bolts.
  - a. **Reject** when:
    - i. The U-bolts are damaged, loose, or the bolts are not at least flush with the nut.
8. Check the coil springs.
  - a. **Reject** when:
    - i. Springs are broken or not properly attached.
    - ii. Springs have been heated, cut, are missing, or altered from OEM specifications.
9. Visually inspect the sway bars, torsion bars, and tracking components for damage.
  - a. **Reject** when:
    - i. Any sway bar, torsion bar, or any tracking component is loose, cracked, bent, or disconnected.
    - ii. Bushings are missing, worn, or distorted so that looseness is present.
10. Check the control arms for cracks, bends or breakage.
  - a. **Reject** when:
    - i. The upper or lower control arms are bent, cracked, welded, or otherwise do not meet OEM specifications.
11. Check the bushings for wear or distortion.
  - a. **Reject** when:
    - i. The bushings are missing, worn, or distorted so that looseness is present.
12. Check the spring mounted strut assembly, which must be inspected very closely for leakage, shaft binding, and poor damping.
  - a. **Advise** when:
    - i. The struts have poor damping or leakage.
  - b. **Reject** when:
    - i. There is any wear in the upper mount assembly.
    - ii. There is any horizontal or vertical movement in the lower shaft mounting area.
    - iii. A shaft is bent or binding.



13. Visually inspect shock absorbers for looseness of mounting brackets and bolts.
  - a. **Advise** when:
    - i. The shocks have poor damping or leakage.
  - b. **Reject** when:
    - i. Shock absorbers are missing or disconnected.
    - ii. Mounting brackets, bolts, or bushings are loose, broken, or missing.
    - iii. A shock is bent or binding.

14. Check the CV Axle and axle boots.

- a. **Advise** when:
  - i. The CV boots are cracked or torn.
- b. **Reject** when:
  - i. A CV joint makes popping or clicking noise while turning during test drive.



15. Check the U-joint for wear.

- a. **Advise** when:
  - i. Wear is found in the U-joint.
- b. **Reject** when:
  - i. The U-joint, driveline, or supporting hardware is worn or damaged to the extent that component separation is imminent.



## **SECTION 5 – ALTERED VEHICLES**

**A. When inspecting lowered vehicles, the inspector shall:**

1. Ensure that all replacement parts and equipment are equal to or greater in strength and durability as OEM parts.
  - a. **Advise** when:
    - i. **Fender extenders do not cover full width of a tire.**
  - b. **Reject** when:



- i. Any part of the vehicle, other than tires, rims, or mudflaps, are less than three inches above the ground or contact the ground.
- ii. The fuel tank is exposed to damage without a skid plate.
- iii. Exhaust system brackets are not secure.
- iv. Wheels or tires make contact with the body or other vehicle component.
- v. Tire tread is not fully covered by existing fenders or fender extenders
- vi. Braking, steering, or suspension is modified, disconnected, or changed in any manner that may impair the safe operation of the vehicle.
- vii. Main springs or shocks have been removed to accommodate a hydraulic or air suspension system.
- viii. Headlamps are less than 22 inches from the ground when measured from the ground to the center of the low beam bulb.
- ix. Any light does not meet mounting height specifications as outlined in the Federal Motor Vehicle Safety Standards.
- x. Chassis or suspension components have been altered or changed from OEM that reduces the vehicle stability and safety integrity.

NOTE: all measurements must be taken while the vehicle is on a flat, level surface and while unladen. If the door certification plate has been removed, the vehicle shall be considered to be 4500 lbs. GVWR.

**B. When inspecting lifted vehicles, the inspector shall:**

1. Check the braking and steering system components.
  - a. **Reject** when:
    - i. The braking or steering systems have been altered, modified, disconnected, or changed in any manner that may impair the safe operation of the vehicle.
2. Check vehicle lift by frame height measuring from the ground to the bottom of the frame on the left side of the vehicle under the driver's seat. If the door certification plate has been removed, the vehicle shall be considered to be 4,500 lbs.
  - a. **Reject** when:
    - i. The frame height is greater than 24 inches on a vehicle with a GVWR less than 4,500 lbs.
    - ii. The frame height is greater than 26 inches on a vehicle with a GVWR of 4,500 lbs and less than 7,500 lbs.
    - iii. The frame height is greater than 28 inches on a vehicle with a GVWR of 7,500 lbs or more.
3. Check the body lifts above the frame.
  - a. **Reject** when:
    - i. The lowest part of the body floor is raised more than 3 inches above the top of the frame.
4. Check the vehicle for front and rear axle blocks.
  - a. **Reject** when:
    - i. Axle blocks have been added to the front axle.
    - ii. There are stacked blocks on the rear axle, which includes two blocks that have been welded together.
    - iii. There are stacked frames.



NOTE: Two blocks that have been welded together are still considered to be stacked blocks and in violation of UCA 41-6a-1630 (d).

5. Check vehicle tire and wheel track.
  - a. **Advise** when:
    - i. A fender or fender extender does not cover the full width of a tire.
  - b. **Reject** when:
    - i. The tire tread protrudes beyond the original fender or fender extender.
    - ii. Spacers are used.
6. Check the mudflaps if the vehicle has been altered, which includes the addition of larger tires and suspension lift kits.
  - a. **Advise** when:
    - i. Fenders do not cover the top 50% of the tire when required.
    - ii. Mudflaps are not present on the rear wheels of a vehicle that has been altered from its original OEM specifications.
    - iii. Rear mudflaps are not directly aligned with the tire and do not cover the full width of the rear tires and have a ground clearance of not more than 50% of the diameter of a rear-axle wheel, under any conditions of loading the vehicle.
7. Check lights for proper height requirements.
  - a. **Reject** when:
    - i. Any light does not meet mounting height specifications as outlined in the Federal Motor Vehicle Safety Standards.
8. Check fuel tank.
  - a. **Reject** when:
    - i. The fuel tank is exposed with no impact protection.

## **SECTION 6 – BRAKES**



- A. **Safety inspection stations are not required to use a computerized brake testing device as a mandatory piece of inspection equipment**
- B. **When using a plate brake tester, Safety inspection stations and inspectors shall:**
  1. Follow the equipment manufacturer procedures for testing.
  2. Be certified by the equipment manufacturer or an authorized agent of the division.
  3. Renew the inspector certification every three years.

4. Display the inspector certification card for the equipment being used in a prominent location.
5. Display the computerized brake testing equipment certification in a prominent location.
6. Ensure the manufacturer has certified the equipment annually.
7. Pull two wheels upon the failure of the plate brake test to check brake components.
  - a. **Reject** when:
    - i. Vehicle fails the plate brake test, even if the vehicle has adequate pad and or shoe thickness.
8. Complete a visual two-wheel inspection of brake components when requested by a customer.
9. Display at the station a sign in a conspicuous location with the following components:
  - a. The sign must be 14 X 24 inches.
  - b. Lettering shall be one inch in vertical height and not less than one quarter of an inch in width.
  - c. Contain a statement with the Station Name and Station Number followed by the quotation "only uses a computerized Plate Brake Tester to inspect the braking system efficiency of a vehicle for a safety inspection. This test does not measure brake lining thickness or condition of the drum / rotor. However, at the customer's request, we will pull two wheels for a visual check of the braking system (per Utah Safety Inspection requirements)."
10. If it failed on a plate brake tester, the vehicle must pass safety inspection on a plate brake tester.

**D. When conducting a visual inspection of a vehicle's brake system, the inspector shall:**

Visual inspection through the wheel openings is not an approved inspection procedure for vehicles less than 10,000 lbs. GVWR and does not meet the safety inspection requirements.

1. Remove at least one front and one rear wheel for a brake inspection on all vehicles less than 10,000 lbs. GVWR.
  - a. Vehicles over 10,000 lbs. GVWR are not required to have wheels pulled if the vehicle is equipped with inspection ports/slots.
2. Inspect the brake drum, linings, pads, discs, calipers, and the condition of all mechanical components.
  - a. Visual inspection through the wheel openings is not an approved inspection procedure.
  - b. Adjustment slots are not adequate for inspecting brakes or if the vehicle has open brake drums.

**E. When inspecting the hydraulic brake system of a vehicle, the inspector shall:**

NOTE: Some manufacturers allow for less than 20% pedal reserve. If unsure, check manufactures specifications.

1. Test the pedal reserve according to the manufacture's specifications.
  - a. **Reject** when:
    - i. There is less than 20% of the total available pedal travel when the brakes are fully applied.

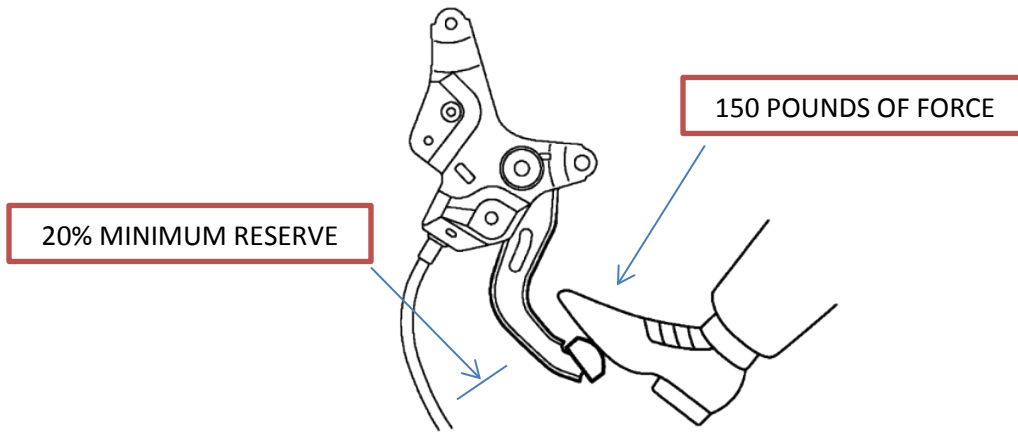

2. Check the wheel cylinders for leakage.
  - a. **Reject** when:
    - i. Any wheel cylinders leak.
3. Inspect hydraulic hoses and tubes for exposed fabric cord, flattened, restricted, or unsecured lines.
  - a. **Reject** when:
    - i. Hoses or tubing are cracked, leaking, or show exposed fabric cord, flattened, restricted, or are unsecured.
    - b. Brake hoses must be DOT approved and cannot be altered.
4. Inspect master cylinder for leakage and fluid level.
  - a. **Reject** when:
    - i. Master cylinder leaks or fails to operate properly.
    - ii. Master cylinder is below the add line or less than 3/4 full, whichever is less.
    - iii. Master cylinder gasket is damaged.

**E. When inspecting the dual hydraulic circuits of a vehicle, the inspector shall:**

1. Check any vehicles equipped with a brake warning light and test for operation of light.
  - a. **Reject** when:
    - i. A warning light remains illuminated or comes on when brake pedal is depressed.
    - ii. A warning light does not operate when required.
      1. Most vehicles can be checked by turning the key to the on position.

**F. When inspecting the brakes with vacuum assist of a vehicle, the inspector shall:**

1. Check the condition of vacuum system for collapsed, broken, badly chafed, improperly supported tubes, and loose or broken hose clamps.
  - a. **Reject** when:
    - i. Hoses, tubes, or booster is leaking.
    - ii. The system is collapsed, broken, badly chafed, showing metal or fabric cord.
    - iii. The system is improperly supported or loose.
    - iv. Hoses or tubes are exposed to damage from excessive heat, debris, or rubbing.



2. Determine if the system is operating by turning off engine and depressing the brake pedal several times to deplete all vacuum in the system, and then starting the engine while maintaining pedal force and observe if the pedal falls slightly when the engine starts.
  - a. **Reject** when:
    - i. The service brake pedal does not fall slightly as engine is started and while pressure is maintained on pedal.

**G. When inspecting the brakes with a hydraulic booster of a vehicle, the inspector shall:**

1. Check the integrated Hydraulic Booster. With the ignition key in the off position, depress the brake pedal a minimum of 25 times (50 times on Jeeps with anti-lock brakes) to deplete all residual stored pressure in the accumulator. Depress the pedal with a light foot-force (25 lbs.). Place the ignition key in the on position and allow 60 seconds for the brake warning lights to go out indicating the electric pump has fully charged the accumulator.
  - a. **Reject** when:
    - i. The brake pedal does not move down slightly as the pump builds pressure.
    - ii. The brake warning lights remain on longer than 60 seconds.
2. Check the braking system, while fully charged, for leaks and proper fluid levels.
  - a. **Reject** when:
    - i. Fluid reservoir is below the add line or less than 3/4 full, whichever is less.
    - ii. Has broken, kinked or restricted fluid lines or hoses.
    - iii. Has any leakage of fluid at the pump or brake booster, or on any of the lines or hoses in the system.

**H. When inspecting brake drums of a vehicle, the inspector shall:**

1. Check the condition of the drum friction surface for damage, contamination, and substantial cracks.
  - a. A vehicle may pass inspection with short hairline heat cracks.
  - b. **Reject** when:
    - i. There are substantial cracks, other than short hairline heat cracks, on the friction surface extending to the open edge of the drum.
    - ii. Any part of the brake drum is missing or is in danger of falling away.
2. Check for cracks on the outside of drum.
  - a. **Reject** when:
    - i. A brake drum has external cracks, other than short hairline cracks.
3. Check for mechanical damage.
  - a. **Reject** when:
    - i. There is evidence of mechanical damage other than wear.
4. Check for leaks at all grease or oil seals.
  - a. **Reject** when:
    - i. The leakage of oil, grease, or brake fluid contaminates the brake components.

5. Check the drum diameter.

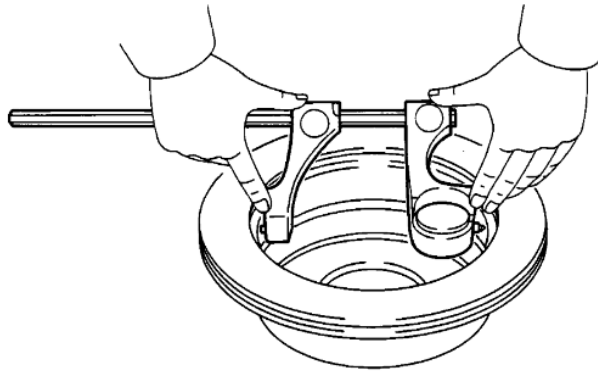

- a. **Reject** when:
  - i. The drum is turned or worn beyond the manufacturer's specifications.

**I. When inspecting brake rotors of a vehicle, the inspector shall:**

1. Check the condition of the rotor friction surface for substantial cracks.
  - a. **Reject** when:
    - i. There are substantial cracks, other than short hairline cracks, on the friction surface extending to open edge of rotor.
    - ii. The friction surface is contaminated with oil or grease.
    - iii. Any part of the brake rotor is missing or are in danger of falling away.
2. Check the rotor thickness.
  - a. **Reject** when:
    - i. The rotor thickness is less than the manufacturer's specifications.

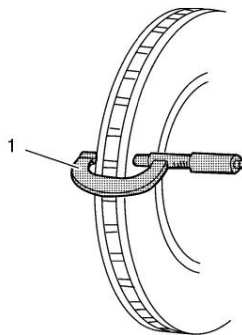

**J. When inspecting the bonded lining and pads of a vehicle, the inspector shall:**

1. Check the primary and secondary lining thickness at the thinnest point.
  - a. **Advise** when:
    - i. The lining thickness is worn to 2/32 inch.
  - b. **Reject** when:

- i. The lining thickness is worn to less than 2/32 inch.

**K. When inspecting the riveted lining and pads of a vehicle, the inspector shall:**

NOTE: Calipers must be removed to accurately measure riveted pads.

1. Check for loose or missing rivets
  - a. **Reject** when:
    - i. Any rivets are loose or missing.
    - ii. The lining thickness is worn to less than 2/32 inch.
2. Check the primary and secondary lining thickness above the rivet head by measuring at the thinnest point with the calipers removed.
  - a. **Reject** when:
    - i. The lining thickness is less than 2/32 inch above any rivet head.

**L. When inspecting the brake linings of a vehicle, the inspector shall:**

1. Check for broken or cracked linings.
  - a. **Reject** when:
    - i. The linings are broken, cracked, or not firmly and completely attached to shoe.
2. Check for contamination of the friction surface.
  - a. **Reject** when:
    - i. The friction surface is contaminated with oil, grease, or brake fluid.
    - b. Once a brake lining has been contaminated, replacement is required.
3. Check for uneven lining wear.
  - a. **Advise** when:
    - i. The lining is uneven or grooved.



**M. When inspecting the mechanical brake components of a vehicle, the inspector shall:**

1. Check for missing or defective mechanical components.
  - a. **Reject** when:
    - i. Mechanical parts are missing, **incompatible**, broken, or badly worn.
2. Check for frozen calipers, rusted or inoperative components, missing spring clips, and defective grease retainers.
  - a. **Reject** when:
    - i. Any mechanical parts are frozen, inoperative, missing, or defective.
    - ii. The backing plate or brake shoe is damaged, restricting free movement of the brake shoe.
3. Check for restriction of shoe movement at the backing plate and for binding between the brake shoe and anchor pins.
  - a. **Reject** when:
    - i. The shoes and anchor pins are improperly positioned or misaligned.

**N. When inspecting the parking brake of a vehicle, the inspector shall:**

Park/Emergency brake light indicator DOES NOT need to illuminate



1. Check holding ability.
  - a. **Reject** when:
    - i. The parking brake does not operate or fails to hold the vehicle.
2. Check the ratchet or the locking device.
  - a. **Reject** when:
    - i. The ratchet, pawl or other locking device fails to hold the brake in an applied position.



**O. When inspecting the Anti-Lock Brakes (ABS) of a vehicle, the inspector shall:**

1. Check the ABS warning light and system for proper operation.
  - a. **Advise** when:
    - i. The ABS light fails to light, fails to shut off after 60 seconds, or when 5 rapid beeps are heard when ignition switch is turned to the on position.
    - ii. ABS components are broken, missing, or disconnected.

**SECTION 7 – LIGHTING**



NOTE: Lenses that are patched with another automotive lens piece is an acceptable repair, so long as it is glued on and permanent. Any other repairs that are patched, taped, or covered with any other foreign material **MUST BE REJECTED**.

NOTE: Utah law states lighting devices shall not be used if they “tend to change the original design or performance” of the original device (UCA 41-6a-1618).

NOTE: High intensity lighting (HID) components cannot be installed in vehicles manufactured with a halogen system. The electrical components are not intended to be interchangeable.

NOTE: Auxiliary Lighting is no longer part of the safety inspection

**A. When inspecting the headlamps of a vehicle, the inspector shall:**

1. Check headlamp from proper mounting.
  - a. **Reject** when:

- i. Mounting brackets are loose, missing, or damaged in any way so that a headlamp cannot be properly and securely mounted.
    - ii. A vehicle headlamp is lower than 22 inches or exceeds 54 inches, measured from the ground to the center of the headlamp.
  - 2. Check headlamp for proper aim and lighting by using a mechanical headlamp aiming device or by checking light at 10 feet measured from the front of the vehicle to a wall.
    - a. **Reject** when:
      - i. Headlight aim deviates more than four inches in any direction.
      - ii. A headlamp is less than 22 inches or greater than 54 inches measured from the ground to the center of the low beam.
      - iii. A headlamp fails to light properly.
      - iv. A headlamp projects other than white light.
      - v. A headlamp is not marked USDOT approved.
      - vi. An aftermarket headlight, including a high intensity discharge kit, does not comply with Federal Standards (CFR 571).
  - 3. Check headlamps for holes, breakage, and non-factory colored covers or non-transparent covers.
    - a. **Advise** when:
      - i. A headlamp has minor holes or cracks in the headlight lens.
    - b. **Reject** when:
      - i. A headlamp covering not approved by the department is placed on or in front of any headlamp, or a factory-installed light or cover is faded or painted to the point that components inside are not distinguishable.
      - ii. A headlamp cover is broken or missing.
      - iii. A headlamp cover is tinted, colored, or painted other than clear.
  - 4. Check the dimmer switch for proper functioning and ensure that both high and low beams function.
    - a. **Reject** when:
      - i. The dimmer switch fails to work properly.

**B. When inspecting the backup lights of a vehicle, the inspector shall:**

- 1. Check the backup lights for proper functioning.
  - a. **Advise** when:
    - i. The backup lights are missing or fail to light.
  - b. **Reject** when:
    - i. The backup lights remain illuminated when transmission is not in reverse.

**C. When inspecting the hazard warning lamps of a vehicle, the inspector shall:**



- 1. Check the hazard warning lamps for proper functioning.
  - a. **Reject** when:
    - i. The hazard warning lamps fail to function properly.
    - ii. There is any tinted cover over the lens.

**D. When inspecting a vehicle's interior lamps, the inspector shall:**



- 1. Check the interior lamps for proper functioning.
  - a. **Reject** when:

- i. Turn signal indicators, high beam indicator, or brake warning indicator fails to function.

This section does not apply to Park/Emergency brake light indicators.

NOTE: ILLUMINATED CHECK ENGINE LIGHT IS NOT A VIOLATION.

**E. When inspecting the vehicle's parking lamps, the inspector shall:**

1. Check the parking lamps for proper functioning.
  - a. **Reject** when:
    - i. Parking lamps fail to function properly or display an unapproved color.
    - ii. Any tinted cover is over the lens.

**F. When inspecting the side marker lamps of a vehicle, the inspector shall:**

1. Check the side marker lamps for proper functioning and color.
  - a. **Reject** when:
    - i. Side marker lamps are not functioning properly;
    - ii. Side marker lamps or side reflectors are not the correct color, which must be yellow or amber on the front of the vehicle and red on the rear of the vehicle.
    - iii. There is any tinted cover over the lens.

**G. When inspecting the tail lamp assembly of a vehicle, the inspector shall:**

1. Check the tail lamp assembly for proper lens and required reflex reflectors.
  - a. **Reject** when:
    - i. Rear lenses do not produce red light, are painted, or covered by any tinted cover.
    - ii. Lenses are missing required reflectors.
    - iii. There is tinting or material that obstructs the original design of the light.
2. Check lens covers for breakage.
  - a. **Reject** when:
    - i. A tail lamp lens is broken to the extent that any white light shows through the broken area.
    - ii. There is a tinted cover or temporary patch.
3. Check for the proper operation.
  - a. **Reject** when:
    - i. Tail lamps fail to light properly.
4. Check for proper mounting.
  - a. **Reject** when:
    - i. Tail lamps are not securely mounted.
5. Check for visibility.
  - a. **Reject** when:
    - i. Lamps are not visible from a distance of 500 feet in normal light.

**H. When inspecting the stop lamps of a vehicle, the inspector shall:**



1. Check the stop lamps for proper color.
  - a. **Reject** when:
    - i. Stop lamp lens does not produce a steady burning red light.
    - ii. Is painted or tinted.
    - iii. Has any cover that partially or entirely obstructs the original design of the light.
    - iv. A stop lamp is a blue dot tail light.
2. Check the stop lamps for breakage.
  - a. **Reject** when:
    - i. A stop lamp is broken to the extent that white light is visible to the rear.
    - ii. There is a tinted cover or a temporary patch.
3. Check for the correct operation of stop lamps.
  - a. **Reject** when:
    - i. A stop lamp does not operate when required.
    - ii. A stop lamp fails to light properly.
4. Check for proper stop lamp mounting.
  - a. **Reject** when:
    - i. Stop lamps are not securely mounted.
5. Check the visibility of stop lamps.
  - a. **Reject** when:
    - i. A stop lamp is not visible from a distance of 500 feet in normal light.
    - ii. LED lights have less than 50% of the diodes illuminated.
    - iii. Stop lamp lens does not produce a steady burning red light.
    - iv. Is painted or tinted.
    - v. Has any cover that partially or entirely obstructs the original design of the light.
6. Check center high-mounted stop lamps, if applicable.
  - a. Center high-mounted stop lamps are required on all passenger vehicles manufactured after September 1985.

**NOTE:** Some passenger vans and SUV's manufactured prior to 2003 may have center brake lights mounted under AS-3 privacy glass. These vehicles pass safety inspection as long as no aftermarket tint has been applied to the glass.

- b. Trucks whose overall width is less than 80 inches and GVWR is 10,000 pounds or less, manufactured after September 1, 1993, must be equipped with a high-mounted stop lamp.
- c. Trucks greater than 80 inches in overall width and 10,000 pounds GVWR do not require a high-mounted stop lamp.
- d. A truck equipped with a camper shell at the time of the inspection that covers the center high-mounted stop lamp is acceptable.
- e. A truck shell that was manufactured with a center high-mounted stop lamp is required to function if the truck is equipped with a high-mounted stop lamp.
- f. **Reject** when:

- i. A center high-mounted stop lamp is not present when required.
- ii. A center high-mounted lamp fails to light.
- iii. Any aftermarket tint has been applied over the center high-mounted stop lamp.
- iv. LED lights have less than 50% of diodes illuminated.
- v. Lens does not produce a steady burning red light.
  - 1. Unless equipped with a continuously flashing light system which causes the stop lamp to pulse rapidly for no more than five seconds when the brake is applied and then converts to a continuous light as a normal stop lamp until the time that the brake is released.
- vi. Is painted.
- vii. Has a cover that partially or entirely obstructs the original design of the light.

**I. When inspecting the turn signal operation of a vehicle, the inspector shall:**

- 1. Check the turn signals on all vehicles manufactured in 1956 and later.
  - a. **Advise** when:
    - i. One of the two bulbs fails to illuminate in a two-bulb system.
  - b. **Reject** when:
    - i. The vehicle is not equipped with proper signals.
    - ii. A turn signal fails to function.
- 2. Check the switch for proper functioning.
  - a. **Advise** when:
    - i. The switch does not cancel automatically for vehicles manufactured in 1956 or later.
  - b. **Reject** when:
    - i. The turn signal lever needs to be held in the on position.
- 3. Check the condition of the lens.
  - a. **Reject** when:
    - i. A turn signal lens is tinted, painted, broken or missing.
    - ii. Any tinted cover or foreign material is over the lens.
    - iii. There is a temporary patch on the cover or lens.
- 4. Check for proper mounting.
  - a. **Reject** when:
    - i. The turn signals are not securely mounted.
- 5. Check for the proper color of lens and bulbs.
  - a. **Reject** when:
    - i. Turn signal colors are not red, yellow, or amber in the rear of the vehicle.
    - ii. Turn signal color is not amber in the front of the vehicle.
    - iii. A turn signal lens or bulb is painted.
- 6. Check for visibility of lens.
  - a. **Reject** when:
    - i. Turn signals are not visible from a distance of 100 feet in normal light.

NOTE: Lighting requirements for all vehicles (FMVSS 108). No other colors than those notated are permissible. Neon lights are not acceptable.



LIGHT	COLOR	LOCATION	HEIGHT	NUMBER
Headlamps	White	On the front	Not less than 22 inches nor more than 54 inches	2 or 4
Turn Signal Lamps	Amber Red or Amber	At or near the front, at the same height, symmetrically about the vertical centerline, as far apart as practicable	Not less than 15 inches, nor more than 83 inches	2 or more
Tail lamps	Red	On the rear, at the same height, symmetrically about the vertical centerline, as far apart as practicable	Not less than 15 inches, nor more than 72 inches	2
Stop Lamps	Red	On the rear, at the same height, symmetrically about the vertical centerline, as far apart as practicable	Not less than 15 inches, nor more than 72 inches	2
Backup Lamp (not required on trailer)	White	On the rear	No requirement	1 or more
Hazard Lamp (same lamp as turn signal)	Amber red or Amber	Front/Rear	15" - 83" (F) (R)	2 or more(F) 2 or more (R)
Rear Reflector	Red	Rear	15" – 60"	2 or more
Side Marker Lamp (not required on truck-tractor)	Amber (F) Red (R)	On each side as far to the front as practical, and as far to the rear as practical	15" minimum for Front and Rear	1 front 1 rear both sides
Side Reflector (not required on truck-tractor)	Amber Red	On each side as far to the front as practical, and as far to the rear as practical	15"-60" 15"-60"	1 each side 1 each side
Intermediate Side Reflector (if vehicle overall length is 30' or greater)	Amber	Side near center	15"-60"	1 each side
Intermediate Side Lamp (if vehicle overall length is 30' or greater)	Amber	Side near center	15" minimum	1 each side
Parking Lamp (only if vehicle is less than 80" wide)	Amber or White	Front (not required on trailer)	15"-72"	2 or more
Identification Lamp	Amber	Front, spaced 6"-12" on center (not required on trailer)	As high as practical	3
	Red	Rear (not required on truck-tractor)	As high as practical	3

Clearance Lamp	Amber	Front, at widest point	As high as practical	2
	Red	Rear, at widest point (not required on truck-tractor)	As high as practical	2
License Plate Lamp	White	On the rear to illuminate license plate from top or sides	No requirement	1 or more

## SECTION 8 – ELECTRICAL SYSTEM

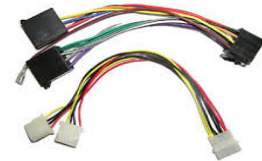

### A. When inspecting the electrical system of a vehicle, the inspector shall:

1. Check the horn.
  - a. **Advise** when:
    - i. The horn is not securely fastened.
  - b. **Reject** when:
    - i. The horn does not function properly or is not audible under normal conditions at a distance of at least 200 feet.
2. Check the electrical switches and wiring.
  - a. **Advise** when:
    - i. Electrical switches fail to function as designed for OEM required equipment.
    - ii. Connections show signs of corrosion.
    - iii. Permanent connection wires are not soldered **and** insulated.
  - b. **Reject** when:
    - i. Wiring insulation is worn or rubbed bare.
3. Check the automatic or manual transmission safety starting switch.
  - a. **Reject** when:
    - i. The starter operates in any gear other than "P" or "N" for an automatic transmission.
    - ii. The vehicle starter operates without the clutch depressed for a manual transmission, when equipped with a neutral safety switch.
4. Check for battery securement.
  - a. **Reject** when:
    - i. A battery is not properly secured.

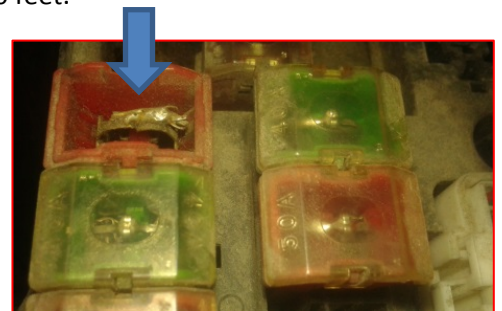

NOTE: Battery shall not be secured by a temporary repair (i.e. Bungee Cord, Rope, zip-ties, duct tape, etc.).

## **SECTION 9 – VEHICLE WINDOWS**



NOTE: Architectural glass and Plexiglas are prohibited

### **A. When inspecting the windshield of a vehicle, the inspector shall:**



1. Check the windshield for appropriate "AS" certification number.
  - a. **Reject** when:
    - i. The windshield is missing.
    - ii. The windshield does not have AS-1, AS-10, or AS-14 markings.
2. Visually inspect the windshield for scratches, cloudiness, etching, or other marks.
  - a. **Reject** when:
    - i. The windshield glass is scratched, discolored, clouded, or pitted to a level that obscures vision.
    - ii. The windshield cloudiness is more than one inch from each side edge, more than four inches down from the top edge, or more than three inches up from the bottom edge.
    - iii. The windshield has decorative etching that is not OEM.
3. Check the windshield for damage, unauthorized tinting, signs, or other non-transparent materials.
  - a. **Reject** when:
    - i. The windshield has outright breakage, which includes shattered glass on either the inside or outside surface, or any broken glass leaving sharp or jagged edges.
    - ii. Any crack intersects with another crack within the acute area.
    - iii. Any damage within the acute area that cannot be covered by a disc 3/4 inch in diameter (a penny).
    - iv. Any damage in the acute area that is within 3 inches of any other damage in the acute area.
    - v. Windshield allows less than 70% light transmittance or any sign, poster, or other non-transparent material is present below the AS-1 line or four inches down from the top of the windshield, whichever is lower.
    - vi. Any transparent material becomes obscured or impairs the drivers vision and is more than one inch in from each side edge, more than four inches down from the top edge, or more than three inches up from the bottom edge.

4. Non-transparent material is allowed in the lower left-hand corner of the windshield provided, it does not extend more than 3 inches to the right of the left edge or more than 4 inches above the bottom edge of the windshield in accordance with Section 41-6a-1635.

NOTE: All measurements are taken on the outside of glass, from the edge where the glass and molding

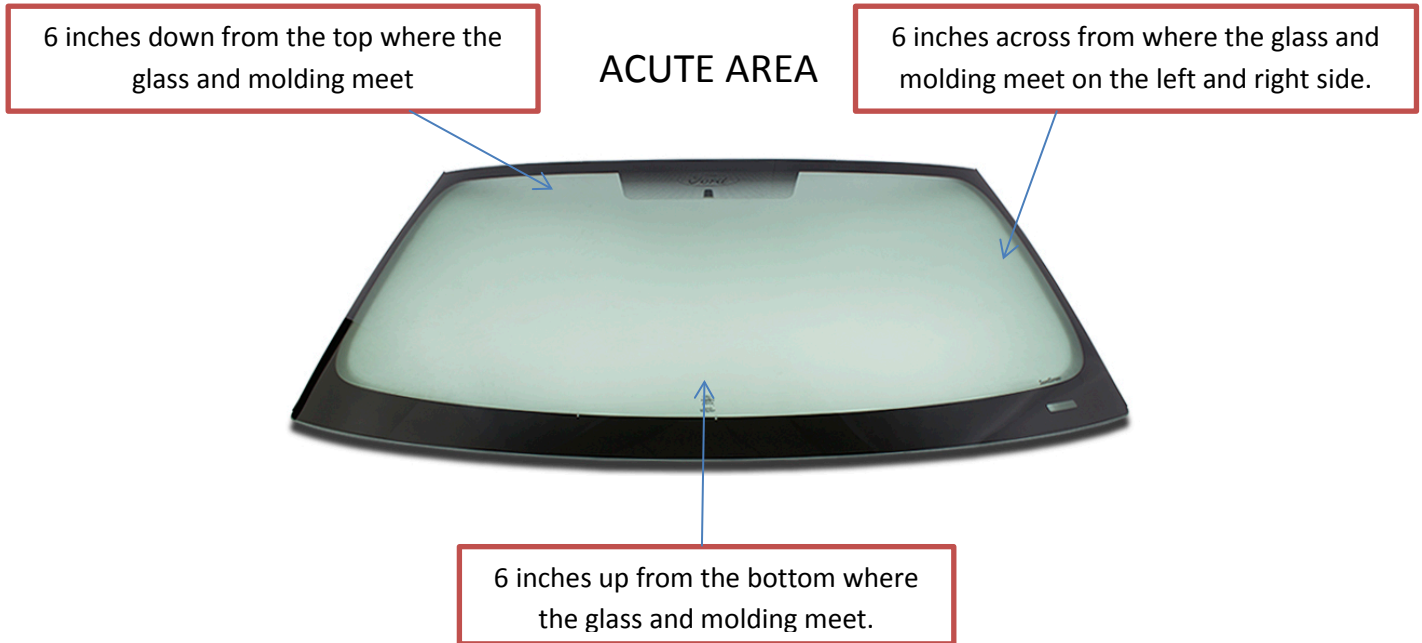

NOTE: All light transmittance testing will allow a 3% variance.

**B. When inspecting the windshield defroster of a vehicle, the inspector shall:**



1. Verify a vehicle manufactured after January 1, 1969 is equipped with a windshield defroster system.
2. If applicable, turn on windshield defroster fan switch and inspect for heated air blowing over the inside of the windshield.
  - a. **Reject** when:
    - i. A vehicle manufactured after January 1, 1969 is not equipped with a windshield defroster system.
    - ii. The defroster fan fails to function or the fan functions but a stream of heated air cannot be felt blowing against the proper area of the windshield.

**C. When inspecting the windshield wipers of a vehicle, the inspector shall:**



1. Check for satisfactory operation of the windshield wipers (if vacuum operated, the engine must be idling).
  - a. **Advise** when:
    - i. **Wipers fail to return to the park position.**
  - b. **Reject** when:
    - i. Any wiper fails to function properly, **other than streaking from wiper blades.**
    - ii. A vehicle originally equipped with two windshield wipers has been modified to use one wiper.
    - iii. A vehicle manufactured after January 1968 does not have a two or more speed system.
2. Check the wiper blades for damaged, torn, or hardened rubber elements.
  - a. **Reject** when:
    - i. The wiper blades show signs of physical breakdown of the rubber wiping element.
3. Check for damaged metal parts of wiper blades or arms.
  - a. **Reject** when:
    - i. The wiper blades or arms are missing or damaged to the extent that they do not function properly.
4. Check for proper contact of blades with windshield.
  - a. **Reject** when:
    - i. A wiper blade fails to contact the windshield firmly.



**D. When inspecting the windshield washers of a vehicle, the inspector shall:**

NOTE: Rear window wipers are optional and do not need to work.

1. Verify a vehicle manufactured after May 1966 is equipped with a windshield washer system.
2. If applicable, check for proper operation of hand or foot control and that an effective amount of fluid is delivered to the windshield.
  - a. **Reject** when:
    - i. A vehicle manufactured after May 1966 is not equipped with a windshield washer system.
    - ii. The windshield washer system fails to function properly, including cracked or broken hoses or if the fluid reservoir is unable to hold fluid.

**E. When inspecting the front side windows of a vehicle, the inspector shall:**

1. Check the operation of the driver window and front passenger window.
  - a. **Advise** when:
    - i. The driver window cannot be readily opened to permit arm signals.
  - b. **Reject** when:

- i. The driver or front passenger window fails to roll up.
  2. Check the driver and front passenger windows for tinting or shading, scratches, discoloration, and cloudiness.
    - a. **Advise** when:
      - i. The driver or front passenger window is scratched, discolored, or clouded, but the driver's view of the side mirrors is unobscured.
    - b. **Reject** when:
      - i. There is any tinting or non-transparent material added to the windows to the immediate left or right of the driver's seat that allows less than 43% light transmittance.
      - ii. The front left and right side windows are scratched, discolored, clouded, or etched with non-OEM markings to a level that obstructs the drivers' view of the side mirrors.
      - iii. The right side mirror is missing when any window is tinted.
      - iv. Windows are covered by or treated with a material, which presents a metallic or mirrored appearance when viewed from the outside of the vehicle.
  3. Check the driver and front passenger windows for breakage.
    - a. **Reject** when:
      - i. Any glass is broken, shattered, or jagged.
  4. Check the wind deflectors (bubbles) when present.
    - a. **Reject** when:
      - i. a wind deflector on the driver or front passenger window is tinted to allow less than 43% light transmittance, or when deflector and window are both tinted to allow less than 43% light transmittance.

NOTE: This applies only to wind deflectors on the front, left and right windows of the driver, which block visibility to the left and/or right mirror.

**F. When inspecting the rear side window of a vehicle, the inspector shall:**

1. Check the windows behind the driver and passenger doors for tinting or for material that presents a metallic or mirrored appearance.
  - a. **Reject** when:
    - i. Any window is covered by or treated with a material that presents a metallic or mirrored appearance when viewed from the outside of the vehicle.
    - ii. Any glass is broken, shattered, or jagged.
    - iii. Windows do not meet AS standards.
    - iv. Center high-mounted brake light is covered with aftermarket window tint or is not visible.
2. All windows behind the driver do not have window tint limits.
3. Check the vehicle for rearview mirrors.
  - a. **Reject** when:
    - i. The vehicle lacks a left rearview mirror that meets OEM standards.
    - ii. The vehicle has only one review mirror; or
    - iii. Lacks a right outside rearview mirror if the vehicle has any amount of tint on its windows.

## **SECTION 10 – BODY**



### **A. When inspecting the body of a vehicle, the inspector shall:**

1. Check the vehicle body for protruding metal parts, moldings, and other body parts that may protrude from vehicle, creating a hazard.
  - a. **Reject** when:
    - i. Metal, molding, or any other body part protrudes from the surface of the vehicle and creates a hazard.
2. Check parts and accessories for proper securement.
  - a. **Reject** when:
    - i. Parts or accessories are not properly secured.

### **B. When inspecting bumpers of a vehicle, the inspector shall:**

1. Check bumpers to ensure it meets OEM specifications in vertical height, are centered on the vehicle's centerline, connected securely to the vehicle frame, and extend the entire width of the vehicle wheel track.
  - a. **Reject** when:
    - i. Bumpers are not 4.5 inches in vertical height.
    - ii. Bumpers do not extend to the entire width of original body wheel track.
    - iii. Bumpers are missing, improperly attached, broken, or have portions protruding which create a hazard.
    - iv. Bumpers are not made from a material that is strong enough to effectively transfer impact.
  - b. A pickup truck is required to meet the requirements of this section even though it may be sold or purchased without a rear bumper meeting OEM standards.
  - c. Roll pans are not bumpers and are only acceptable when a material is concealed behind the roll pan that meets the strength, vertical height, and securing requirements of a rear bumper. This material must extend the width of the wheel track and must meet all of the requirements of a rear bumper.

NOTE: Pickup trucks are designed and manufactured for a rear bumper with OEM standards. However, pickup trucks can be sold and may be purchased without a rear bumper. The vehicle owner has the responsibility for compliance with Utah law (41-6a-1632 UCA) when the vehicle is operated on Utah roads.

NOTE: Roll pans are not bumpers and are only acceptable when a material is concealed behind the roll pan that meets the strength, vertical height, and securing requirements of a rear bumper. This material must extend the width of the wheel track and meet the requirements of a rear bumper.

**C. When inspecting the fenders of a vehicle, the inspector shall:**

1. Check for removal or alteration of front and rear fenders.
  - a. **Advise** when:
    - i. Any fender has been removed or altered to such extent that it does not cover the entire width and upper 50% of the tire.



NOTE: Fenders, bumpers and hoods are optional on replica vehicles 1935 and older. See Section 15 Custom (Replica) Vehicles on pages 77-78.

**D. When inspecting the seats of a vehicle, the inspector shall:**

1. Check seats for proper operation of adjusting mechanism and to see that the seats are securely anchored to the floor.
  - a. **Reject** when:
    - i. Seats are not anchored to the floorboard.
    - ii. The seat adjusting mechanism slips out of set position.
    - iii. The seat adjusting mechanism does not function properly.
    - iv. Any driver or passenger seat back is broken or disconnected from the base so that it will not support a person's full weight.
    - v. Seat belts are not installed when required or are inoperative when present.
    - vi. Seat belts are cut, torn, frayed, or otherwise damaged.
2. Check the motorized safety belts for proper function.
  - a. **Advise** when:
    - i. A motorized seat belt does not function as designed.
  - b. **Reject** when:
    - i. Motorized seat belts fail to lock in the rear position.



**E. When inspecting the air bags of a vehicle, the inspector shall:**



1. Check the Air Bag Readiness Light.
  - a. **Advise** when:
    - i. Air bag indicator fails to light in the manner prescribed by the manufacturer, continuously flashes, remains illuminated, or if five sets of "beeps" are heard concurrent with indicator failing to light.
2. Check the air bags.
  - a. **Reject** when:
    - i. An air bag has been deployed or is not present when originally equipped on the vehicle.



**F. When inspecting the floorboards of a vehicle, the inspector shall:**



1. Check the floorboard in both the occupant compartment and trunk for rusted areas or holes that could permit entry of exhaust gases or will not support occupants adequately.

- a. **Reject** when:

- i. Any area of the floorboard is rusted through sufficiently to cause a hazard to an occupant.
    - ii. Exhaust gases could enter the occupant compartment or trunk.



2. Check the space between the floor pan and frame for body lifts.

- a. **Reject** when:

- i. The lowest part of body floor is raised more than three inches above top of frame.

#### **G. When inspecting the doors of a vehicle, the inspector shall:**

1. Check the doors and door components for proper operation.

- a. **Reject** when:

- i. Doors are missing, unless the vehicle manufacturer specially designed the doors to be removed.
    - ii. Door parts are missing, broken, or sagging to the extent that the door cannot be opened and closed properly.
    - iii. Any interior and exterior door handles are not present or do not function as designed by the manufacturer.
  - b. Shaved door handles with automatic releases are allowed provided that when the engine is running and the vehicle is in drive, the wireless remote cannot activate door release switch.

#### **H. When inspecting the hood of a vehicle, the inspector shall:**

1. Check all vehicles for hood or engine cover.

- a. **Reject** when:

- i. The hood or engine cover is missing.
    - ii. The hood is unable to be opened.

2. Check the hood and open it to check the safety catch for proper operation.

- a. **Reject** when:

- i. The secondary or safety catch does not function properly.

3. Check for proper hood operation.

- a. **Reject** when:

- i. The hood latch does not securely hold the hood in its proper fully closed position.

4. Check for aftermarket hood scoop or air intake.

- a. **Reject** when:

- i. A hood scoop, air intake, or any engine component is higher than four inches above the top of the hood.
    - ii. Moving parts are exposed above the hood.

**I. When inspecting the frame of a vehicle, the inspector shall:**

1. Check the frame and ensure that any repairs made to the frame meet OEM specifications.
  - a. **Reject** when:
    - i. There is any broken or cracked frame component.
    - ii. The frame is rusted through.
    - iii. The frame has been cut or portions of the frame have been removed, **drilled**, or bent, affecting the strength or integrity of the frame.
    - iv. Repairs made to the frame do not meet OEM specifications.



**J. When inspecting the mounts of a vehicle, the inspector shall:**

1. Check all mount components, including motor mounts, transmission mounts, and drive train mounts.
  - a. **Advise** when:
    - i. Heat cracks are present.
  - b. **Reject** when:
    - i. Any mount bolts or nuts are broken, loose, or missing.
    - ii. The rubber cushion is separated from the metal plate of any mount.
    - iii. There is a split through the rubber cushion.
    - iv. The engine or transmission is sagging to the point where the mount bottoms out or there is engine misalignment to the point of a drive train component compromise.
    - v. Fluid-filled mounts are leaking (leakage must be verified from the mount).

**K. When inspecting the exterior rearview mirrors of a vehicle, the inspector shall:**

1. Check exterior mirrors from the driver's position for a clear and reasonably unobstructed view to the rear.
  - a. **Verify one driver-side mirror that meets OEM standards is equipped on a vehicle manufactured after January 1968.**
  - b. Verify one passenger-side mirror is equipped on a vehicle with tinted windows or an obstructed rear view.
  - c. **Reject** when:
    - i. The required mirrors are not present.
    - ii. **Driver-side mirror does not meet OEM standards.**
2. Verify mirrors are in the correct location and are mounted securely.
3. Check for cracks, sharp edges, or unnecessary protrusion.
  - a. **Reject** when:
    - i. Mirrors are loose enough that the driver's rear vision could be impaired.
    - ii. Mirrors are cracked, pitted, or clouded to a level that obscures the driver's rear vision.
    - iii. Mirrors will not maintain a set adjustment.
    - iv. Mirrors do not allow 200 feet of rear visibility.

**L. When inspecting the interior rearview mirror, the inspector shall:**

1. Check the mirror (if an interior rearview mirror is required) for proper mounting, location, cracks, sharp edges, and ease of adjustment.
  - a. **Reject** when:
    - i. The interior mirror is loosely mounted.
    - ii. The interior mirror obstructs the drivers' forward vision.
    - iii. The interior mirror does not provide a clear view of the highway at least 200 feet to rear.
    - iv. The interior mirror is cracked, broken, has sharp edges, or rear vision is obscured.
    - v. The interior mirror will not maintain a set adjustment.

NOTE: One mirror on driver's side is required on all vehicles manufactured after January 1968. In addition, a mirror on the passenger side is required when tinting is present or the rear view is obstructed.

**M. When inspecting the speedometer of a vehicle, the inspector shall:**

1. Check the vehicle to ensure that it is equipped with a properly functioning speedometer.
  - a. **Advise** when:
    - i. The speedometer is not functioning properly.



**SECTION 11 – EXHAUST SYSTEM**



NOTE: After Market Muffler Devices: (UCA 41-6a-1626(b)). Every motor vehicle shall at all times be equipped with a muffler or other effective noise suppression system in good working order and in constant operation. A person may not use a muffler cut-out, bypass, or similar device. Excessive or unusual noise is prohibited. (Additional noise ordinances may be enforced by a city and/or county agency).

NOTE: Cherry Bomb/Glass Packs are acceptable noise suppression devices. Resonators alone are not.

**A. The inspector shall examine the vehicle's exhaust system and comply with the following requirements:**

1. Check the manifold, exhaust or header pipe, mufflers, tail pipes, and the supporting hardware.
  - a. **Reject** when:
    - i. The muffler is missing.

- ii. The exhaust system has leaks of any kind on any part of the system, excluding drain holes installed by the manufacturer.
- iii. Any part of the system is not securely fastened or is secured in a manner that is likely to fail, such as using a rope to secure the tail pipe.
- iv. The tail pipes do not extend beyond the outer periphery of the passenger compartment, discharge at any point forward of the passenger compartment, or are severely bent or broken.
- v. The exhaust system passes through any occupant compartment.
- vi. A muffler cutout or similar device is installed.
- vii. Any part of the exhaust system that is located or exposed in a manner that a person will likely be burned or injured.
- viii. Any part of the exhaust system is located so that it would likely result in burning, charring, or damaging the electrical wiring, the fuel supply, or any combustible part of the motor vehicle.

## **SECTION 12 – FUEL SYSTEM**



NOTE: Containers shall be located to minimize the possibility of damage to the container and its fittings. They shall not be mounted directly on roofs or ahead of the front axle or beyond the rear bumper of a vehicle. No part of a container or its appurtenances shall protrude beyond the sides or top of the vehicle. Containers located less than 18 inches from the exhaust system, the transmission, or a heat-producing component of the internal combustion engine shall be shielded by a vehicle frame member or by a noncombustible baffle with an air space on both sides of the frame member or baffle. For tanks that are installed inside a passenger compartment, they shall be installed in an enclosure that is securely mounted to the vehicle, such as a trunk which is gastight with respect to the passenger compartment and is vented to the outside of the vehicle. Manual shutoff valves shall be designed to provide positive closure under service conditions and shall be equipped with an internal excess-flow check valve designed to close automatically at the rated flows of vapor. The manual shutoff valve when put in the closed position shall stop all flow to and from the container and should be readily accessible without the use of tools, or other equipment. A check valve will not meet this

NOTE: Make sure that the fuel tank is not exposed or unprotected. Tanks that are installed under a vehicle may not be mounted ahead of the front axle or behind the point of attachment of the rear bumper. Tanks shall be protected from physical damage using the vehicle structure, valve protectors or a suitable plastic or metal shield. A tank that is installed in the bed of a truck must be protected with a shield over the top and down any exposed sides. Shields shall be installed in a manner that prevents direct contact between the shield and the fuel tank. The shield shall also prevent the trapping of solid materials or liquids between the shield and tank that could damage the container or its coating. (NFPA 52, 6.3).

### **A. If the fuel system uses diesel or gasoline, the inspector shall:**

1. Check the fuel tank, fuel tank support straps, filler tube, tube clamps, fuel tank vent hoses or tubes, filler housing drain, overflow tube, and fuel filler.

- a. **Reject** when:
  - i. There is fuel leakage at any point or there are escaping gases detected in the system.
  - ii. The fuel tank filler cap is missing.
  - iii. Any part of the system is not securely fastened or supported.
  - iv. There is physical damage to any fuel system component.
  - v. The crossover line is not protected and drops more than two inches below fuel tanks.

**B. If the fuel system uses liquid propane gas, the inspector shall:**

NOTE: The mere presence of a propane odor (Ethyl Mercaptan) does not necessarily mean that a leak exists. An inspection utilizing the soap test with antifreeze must be utilized. Leaks are commonly found in the vaporizer, fuel lines, or fuel line connections.

1. Check the fuel tank, fuel tank support straps, filler tube, tube clamps, fuel tank vent hoses or tubes, filler housing drain, overflow tube, fuel filler cap, and conversion kit installations.
2. Check for leaks by using the soap test with antifreeze.
3. Check that the fuel container is installed in a way to prevent it from jarring loose, slipping, or rotating.
4. Check that containers are located to minimize the possibility of damage to the container and its fittings.
5. Check that containers located less than 18 inches from the exhaust system, the transmission, or a heat-producing component of the internal combustion engine are shielded by a vehicle frame member or by a noncombustible baffle with an air space on both sides of the frame member or baffle.
6. Check that the piping system is installed, supported, and secured in such a manner as to minimize damage due to expansion, contraction, vibration, strains, and wear. Protection to the piping system may be achieved by parts of the vehicle furnishing the necessary protection, a fitting guard furnished by the manufacturer of the container, or by other means to provide equivalent protection.
7. Check that container valves, appurtenances, and connections are protected to prevent damage from accidental contact with stationary objects or from stones, mud, ice, and from damage from the vehicle's overturn or similar accident.
8. For a tank installed inside a passenger compartment, check that it is installed in an enclosure that is securely mounted to the vehicle, such as a trunk which is gas-tight with respect to the passenger compartment and is vented to the outside of the vehicle.
9. Check that manual shutoff valves provide positive closure under service conditions, are equipped with an internal excess-flow check valve designed to close automatically at the rated flows of vapor, stop all flow to and from the container when put in the closed position, and are readily accessible without the use of tools or other equipment. A check valve will not meet this requirement.
10. **Reject** when:
  - a. There is fuel leakage at any point or there are escaping gases detected in the system.
  - b. The fuel tank filler cap is missing.

- c. Any part of the system is not securely fastened, supported, or the tank valve is not shielded.
  - d. There is physical damage, such as excessive denting, corrosion, bulging, gouging, or corrosion, to any fuel system component.
  - e. The fuel lines have any corrosion.
  - f. Welding is present, with the exception of being on saddle plates, lugs, pads or brackets that are attached to the container by the container manufacturer.
  - g. Excessive surface rust on the tank or tank paint coating is in poor condition.
  - h. There is any installation hazard present that may cause a potential hazard during a collision.
  - i. A container is mounted directly on roofs or ahead of the front axle or beyond the rear bumper of a vehicle.
  - j. A container or its appurtenance protrudes beyond the sides or top of the vehicle.
  - k. The vehicle does not have a weather-resistant, diamond shaped label located on the right rear of the vehicle identifying the vehicle as a 'PROPANE' fueled vehicle.
  - l. A data plate (saddle plate) is not present or is not legible on a propane tank.
  - m. Any aftermarket data plates are welded on the tank.
  - n. A check valve is used for a manual shutoff valve.
11. ASME (American Society of Mechanical Engineers) containers are installed permanently to vehicles and are not subject to the DOT inspection requirements.
  12. All liquefied propane gas containers fabricated to earlier editions of regulations, rules, or codes listed in NFPA 5.2.1.1 and of the Interstate Commerce Commission (ICC) Rules for Construction of Unified Pressure Vessels, prior to April 1, 1967, shall be permitted to continue to be used in accordance with Section 1.4 of NFPA.
  13. Containers that have been involved in a fire and show no distortion shall be re-qualified by a manufacturer of that type of cylinder or by a repair facility approved by DOT, before being used or reinstalled.

**SAFETY ALERT:** CNG is lighter than air. It can accumulate in sealed spaces, not vented to atmosphere: Use extreme caution when working around CNG systems. At no time shall an inspector attempt to conduct maintenance or alterations to any alternative fuel system, unless that inspector is currently certified and trained in alternative fuel conversion installations. Working around these systems is extremely dangerous and requires extensive training.

**C. When inspecting a fuel system that uses either CNG or liquefied natural gas, the inspector shall:**

1. Check the fuel tank, fuel tank support straps, filler tube, tube clamps, fuel tank vent hoses or tubes, filler housing drain, overflow tube, fuel filler cap, and conversion kit installations.
2. Check the tank to verify it is protected from physical damage using the vehicle structure, valve protectors or a suitable plastic or metal shield.
3. Check that fuel tank shields do not have direct contact with fuel tanks and prevent trapping of materials that could damage the tanks or its coatings.
4. For fuel tanks installed above, below, or within the passenger compartment, check to verify connections are external or sealed and vented from the compartment.





5. For fuel tanks installed within the passenger compartment, check to verify tanks are vented to the outside of the vehicle with a boot or heavy plastic bag and shall not exit into a wheel well.
6. Check tanks and fuel lines to verify mounting and bracing is away from the exhaust system and supported to minimize vibration and to protect against damage, corrosion, or breakage.
7. Check for identification with a weather-resistant, diamond-shaped label located on an exterior vertical surface or near-vertical surface on the lower right rear of the vehicle, excluding the bumper, inboard from any other markings. The label shall be a minimum of 4.72 inches long by 3.27 inches high.



8. Check that when a manual valve is used, the valve location is accessible, indicated with the words "MANUAL SHUTOFF VALVE".
9. Check that the vehicle bears in the engine compartment a label readily visible identification as a CNG-fueled vehicle, system service pressure, installer's name or company, container retest dates or expiration date, and the total container water volume in gallons.
10. Check for a label located at the fueling connection receptacle with identification as a CNG-fueled vehicle, system working pressure, and container retest dates or expiration date.
11. Check that CNG fuel containers are permanently labeled. Disassembly of the tanks protective shield is not required to verify the label on the tank; it is the vehicle owner's responsibility to provide documentation for a current CNG tank inspection from a CNG certified inspector. The documentation must identify the vehicle and list the CNG tank certification number.
12. Visually inspect CNG fuel containers for damage and deterioration at a minimum of every 36 months or 36,000 miles, whichever comes first, or after a motor vehicle accident or fire.



a. **Reject** when:

- i. There is fuel leakage at any point or escaping gases are detected in the system (odor will be present).
- ii. The fuel tank filler cap or cover is missing.
- iii. Any part of the system is not securely fastened, supported, or shielded to prevent damage from road hazards, slippage, loosening, or rotations.
- iv. Fuel tank is exposed or unprotected.
- v. Tanks that are installed under a vehicle are mounted ahead of the front axle or behind the point of attachment of the rear bumper.
- vi. There is any physical damage to a fuel system component.
- vii. There is any installation hazard present that may cause a potential hazard during a collision.

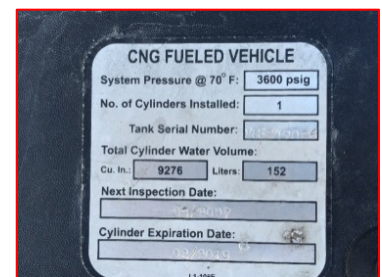
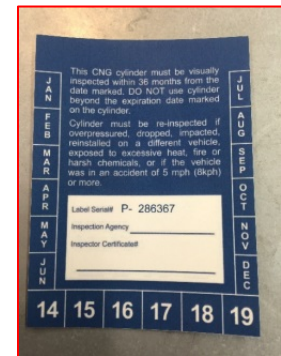

- viii. Any part of the fuel tank or its appurtenances protrudes beyond the sides or top of any vehicle where the tanks can be struck or punctured.
- ix. The vehicle is not labeled as described in section C or in accordance with National Fire Protection Association Pamphlet 52.
- x. A CNG fuel container is not current with its certification in accordance with Federal Motor Vehicle Safety Standards.

## **SECTION 13 – TRAILERS**



- A. Light duty trailers or any trailer, regardless of GVWR, used in the capacity of a Commercial Motor Vehicle as defined in Federal Motor Carrier Safety Regulations shall be inspected per procedures found in Rule R714-162, Equipment Standards for Heavy Truck, Trailer and Bus Safety Inspections:**
  - 1. These inspections shall only be performed by personnel certified in Tractor/Trailer/Bus categories.

## **SECTION 14 – OFF-HIGHWAY VEHICLES**

- A. The inspector shall check vehicles that have been modified for off-road use for compliance with the Safety Inspection Rules, Utah State Law, and Federal Motor Vehicle Safety Standards:**
  - 1. **Reject** when:
    - a. A vehicle does not meet all inspection requirements for a regular passenger vehicle.
    - b. A vehicle does not provide an enclosure or cockpit for the driver and occupants.
    - c. The vehicle has a Baja or T-bar style bumper.

There is a state agency that deals with Off Highway Vehicles (OHV), answers questions, and enforces the laws on them. It is the Utah State Parks and Recreation. Utah State Parks and Recreation's website is: [www.stateparks.utah.gov](http://www.stateparks.utah.gov), then select "Off-Highway Vehicles" from the menu. Local Salt Lake number: (801) 538-7433.



## **SECTION 15 – CUTOM VEHICLES (REPLICA VEHICLES) AND VINTAGE VEHICLES**



### **DEFINITIONS**

1. **"Custom Vehicle"** means:

- a. a motor vehicle that is at least 25 years old and of a model year after 1948; or
- b. was manufactured to resemble a vehicle that is at least 25 years old and of a model year after 1948; and has been altered from the manufacturer's original design; or has a body constructed of non-original materials.
- c. A custom vehicle is primarily a collector's item that is used for: club activities; exhibitions; tours; parades; occasional transportation; and other similar uses. A custom vehicle does not include a motor vehicle that is used for general, daily transportation or is a vintage vehicle (UCA 41-6a-1507).

2. **"Vintage Vehicle"** means a motor vehicle that is 30 years old or older, used primarily as a collector's item, and used for participation in club activities, exhibitions, tours, parades, occasional transportation, and similar uses, but that is not used for general daily transportation.

**A. A vehicle with a vintage license plate does not require a safety inspection. A vehicle may be registered as a vintage vehicle if it is 30 years or older, used primarily as a collector's item and used for participation in club activities, exhibitions, tours, parades, occasional transportation, and similar uses, but is not used for general daily transportation.**

**B. The following are minimum safety equipment requirements for a custom vehicle:**

1. Hydraulic service brakes on all wheels with current vehicle brake and stopping standards.
2. Parking brake operating on at least two wheels on the same axle.
3. Seat belts for all passengers and driver.
4. Sealed beam or halogen headlamps.
5. Brake Lamps.
6. Turn signal lamps and switch.
7. AS-1 safety glass or Lexan.
8. Electric or vacuum windshield wiper in front of the drivers view.
  - a. **Reject** when:
    - i. Any of the above requirements are not met.

**C. Exhaust systems may discharge along the side of the vehicle provided they discharge at a point behind the rear edge of the door and exhaust is directed away from the vehicle.**

- D. The vehicle identification for a custom vehicle shall be a number stamped on the frame of the vehicle. If no such numbers exist, then the requirements as established pursuant to Administrative Rule R873-22M-15 (Department of Motor Vehicles) must be followed in order to pass inspection.
- E. All safety equipment of a replica vehicle shall at least meet the safety standards applicable to the model year of the vehicle being replicated. Any replacement equipment shall comply with the design standards of the replacement equipment's manufacture (41-6a-1507).

NOTE: Fenders, bumpers and hoods are optional on replica vehicles 1935 and older

NOTE: A vintage vehicle does not require a safety inspection (UCA 53-8-205)

## **SECTION 16 – LOW-SPEED VEHICLES**



NOTE: Golf carts are NOT considered Low Speed Vehicles.

“LOW-SPEED VEHICLES”: A four wheeled electric motor vehicle that is designed to be operated at speeds of not more than 25 miles per hour; and has a capacity of not more than four passengers, including the driver. “Low-speed vehicle” does not include a golf cart or an off-highway vehicle (UCA 41-6a-102).

**A. A low-speed vehicle shall meet the requirements found in Section 41-6a-1508 which include:**

1. Headlights.
2. Front and rear turn signals, tail lamps, and stop lights.
3. Reflectors one on the rear of the vehicle and one on the left and right side as far to the rear as practical.
4. A parking brake.
5. A windshield that meets the standards of UCA 41-6a-1635 (see the windshield section of this manual), including a device for cleaning rain, snow, or other moisture from the windshield.
6. An exterior rearview mirror on the driver's side and an interior rearview mirror or an exterior rearview mirror on the passenger side.
7. A low-speed vehicle shall not be altered from the original manufacturer's design.
8. Safety belts (as required by UCA 41-6a-1803).
9. A slow-moving vehicle identification emblem displayed on the rear of the vehicle (UCA 41-6a-1508).
10. An operation braking system as designed by the manufacturer (OEM).
  - a. **Reject** when:

- i. Any of the above requirements are not met.

## **SECTION 17 – RECONSTRUCTED / SALVAGED MOTOR VEHICLES**



- A. A safety inspection is required for the initial application for registration, regardless of the vehicle year for a salvage vehicle (UCA 53-8-205).**
- B. Check all components:**
  - 1. **Reject** when:
    - a. Any components and repairs are not made or installed in accordance with applicable provisions for the particular chassis from the original manufacturer.

## DEFINITIONS (From the Webster's H New Riverside University Dictionary)

**ABSORB** - To take in through or as if to soak in or up.

**ACCUMULATOR** - An automobile storage component.

**ACUTE** - Extremely serious or significant.

**ADAPTER** - A device used to affect operative compatibility between different parts of one or more pieces of apparatus.

**ADEQUATE** - Able to satisfy a requirement.

**ADJUSTMENT** - To change so as to match or fit. To bring into proper relationship.

**ADVISE** – “To Notify” to inform customer of items in an inspection that will pass but will need to be repaired at a later date.

**AFTER-MARKET** -The demand for goods or services associated with the upkeep of a previous purchase.

**AIR-BAG** - An automotive safety device designed to inflate upon collision and prevent passengers from pitching forward.

**ALTERED** - To make different to modify. Alter - Altering.

**ANCHORED** - Something that provides a rigid point of support, stability, or security.

**ANTI-LOCK** - Computerized power surging system that keeps brakes from locking into a frozen position.

**APPLIED** - Put into practice or a particular use.

**APPROPRIATE** – Suitable; fitting.

**ASPIRATED** - To remove liquids or gases with an aspirator. Aspirate - Aspirates  
Aspirating.

**ASSEMBLY** - The combining of manufactured parts to make a completed product, esp. a machine.

**AUTOMATIC** - Acting or operating in a manner essentially independent of external influence or control. Self-regulating.

**AUXILIARY** - Giving or capable of giving assistance or support.

**AXLE** - A supporting shaft or member on which a wheel or pair of wheels revolves.

**BALL BEARING** - A friction-reducing bearing consisting of a ring shaped track containing freely revolving hard metal balls against which

a rotating shaft or other part turns.

**BASE** - The lowest part of a structure as in foundation.

**BEARING** - A part supporting another machine part.

**BENT** - Not straight, crooked.

**BINDING** - To be tight and uncomfortable. To restrain

**BLOCKS** - To support, strengthen, or retain in place by a block.

**BODY** - The passenger and cargo-carrying section of an aircraft, ship or vehicle.

**BOLT** - A fastener having a threaded pin or rod with a head at one end, designed to be inserted through holes in assembled parts and secured by mated nut that is tightened by application of torque.

**BRAKE** - A device for reducing or stopping motion, as of a vehicle, esp. by contact friction.

**BRAKE DRUM** - A metal cylinder to which pressure is applied by a braking mechanism so as to arrest rotation of the wheel or shaft to which the cylinder is attached.

**BRAKE FLUID** - Liquid used in a hydraulic brake system.

**BRAKE LINING** - The covering of a brake shoe or pad.

**BRAKE PAD** - A flat block brake lining that presses against the disc of a disc brake.

**BRAKE SHOE** - A curved block, attached to the brake lining that presses against and reduces or stops the rotation of a wheel or shaft.

**BROKEN** - Forcibly fractured into pieces; shattered.

**BULGES** - A protruding part, as an outward curve or swelling.

**BUMP** - To cause to knock against an obstacle; displace.

**BUMPER** - Either of two metal structures, typically horizontal bars, attached to the front and rear of a car to absorb the impact of a collision, a protective device used to absorb shocks

**BUSHING(S)** - A fixed or removable lining

used to constrain, guide, or reduce friction.

**CALIBRATE** - To check, adjust or standardize systematically the graduations of a quantitative measuring instrument.

**CALIPER** - An instrument composed of two curved hinged legs, used for measuring internal and external dimensions.

**CERTIFICATE** - A document testifying to accuracy or truth.

**CHAFED** - To wear away by friction or irritation.

**CHASSIS** - The rectangular steel frame, supported on springs and attached to the axles, that holds the body and engine of an automotive vehicle.

**CIRCUMFERENCE** - The boundary line of a circle.

**CLAMP** - A device for joining, gripping, supporting or compressing structural or mechanical parts.

**CLEAR(LY)** - Free from what dims, obscures or darkens: Transparent.

**CLOUDED** - A dark blemish or spot, something that obscures.

**COIL** - A series of connecting spirals or connecting rings formed by winding or gathering.

**COLLAPSE** - An abrupt failure of function, strength.

**COMPONENT** - A constituent element, as of a system, a part of a mechanical or electrical complex.

**COMPUTERIZED** - Of or relating to a computer or the use of a computer.

**CONTAMINATED** - To make impure by mixture or contact.

**CORRODE** - To dissolve or eat away gradually by chemical reaction like rust.

**CRACKS** - To break without dividing into parts.

**CRIMPS** - To press or pinch into small regular ridges or folds.

**CUSTOM** - Specializing in the selling of made-to-order goods.

**CUTS** - To separate into parts with or as if with a sharp-edged instrument; sever.

**CYLINDER** - The chamber in which a piston of a reciprocating engine moves.

**DAMPING** - The capacity built into a mechanical or electrical device to prevent

excessive correction and the resulting instability or oscillatory conditions.

**DAMPEN - DAMPENING** - To make slightly wet, moisten.

**DAMAGE** - Impairment of the usefulness or value of person or property.

**DEFECTS**, defective - A fault or imperfection: having a defect: faulty.

**DEFROSTER** - A heating device designed to remove ice or frost or prevent its formation.

**DEPRESS** - To push down.

**DETERIORATED** - To lower or impair in quality, or value.

**DIAMETER** - A straight segment passing through the center of a figure, esp. of a circle or sphere, and terminating at the periphery.

**DISCONNECT** - To interrupt or break the connection of or between.

**DISLOCATED** - To displace from the proper or usual relation- ship with adjoining parts.

**DISTORTION** - To twist out of proper shape or relation; to contort.

**DRAG** - To cause to move with great reluctance, weariness, or difficulty.

**ELECTRICAL** - Of, relating to, or operated by electricity.

**ELONGATED** - To make or grow longer, extended, lengthened.

**ENGINE** - A machine that converts energy into mechanical motion.

**ERRATIC** - Lacking regularity, consistency, or uniformity.

**ETCHING** - To cut into the surface by the action of acid, printing designs or pictures.

**EXCESS** - An amount beyond the normal, sufficient, required or appropriate. Greater or more than the requirement.

**EXPOSED** - To remove protection from, the act of making visible.

**EXTEND** - To stretch or spread out to full length.

**EXTERNAL** - An exterior surface or part.

**FAILURE** - A cessation of proper functioning, a decline in strength or effectiveness.

**FENDERS** - A metal guard over the wheel of an automotive vehicle.

**FLEXIBLE** - Capable of being bent or flexed; pliable.

**FLUSH** - To be cleaned by a rapid brief gush of water.

**FMCSA** – Federal Motor Carrier Safety Administration

**FMVSS** - Federal Motor Vehicle Safety Standard

**FORCE** - To compel through pressure or necessity; to move against resistance.

**FRAME** - A skeletal structure designed to shape and support.

**FRAYED** - To wear away by rubbing, a frayed spot as on fabric.

**FRICTION** - The rubbing of one object or surface against another.

**FROZEN** - Rendered immobile.

**FUNCTIONAL** - Designed for or adapted to a specific function or use. To have or perform a

**GASKET** - A seal or packing used between matched machine parts or around pipe joints to prevent the escape of a gas or fluid.

**HEAVY TRUCK**- Covers vehicles from 26,001 lbs and up.

**HORIZONTAL** - Parallel to or in the plane of the horizon.

**HYDRAULIC** - Of, involving, moved, or operated by a pressurized fluid, esp. water.

**ILLEGAL** - Forbidden by law, by official rules. function.

**INDICATOR** - An instrument as a meter or a gauge for monitoring the operation or condition of a physical system, as an engine.

**INOPERATIVE**- Not working or functioning.

**INSTABILITY** - Lack of stability.

**JAGGED** - Having sharp or ragged projections on a surface or edge.

**JAMMING** - To activate or apply suddenly, as automotive brakes. To cause to lock in inoperable position.

**JOINT (S)** - A point or a position at which two or more things are joined. A configuration in or by which two or more things are joined.

**KINKED** - A tight curl or sharp twist in a wire-like material, typically caused by the tensing of a looped section.

**KNOT**, knots - A compact intersection or interlaced material, as cord, ribbon, or rope. To tie in or become entangled.

**LAMINATED** – Made up of bonded layers.

**LAMP** - A device that generates, heat, light, or therapeutic radiation

**HEIGHT** - The distance from the base to the top of an object.

**LATCH**, latching – To close or lock with or as if to latch.

**LEAF SPRING** - A composite spring used especially in automotive suspensions, consisting of several layers of metallic strips joined to function as a unit.

**LEAK**, leakage - To allow the passage or escape of something through a breach or flaw. A crack or opening that permits something to escape from or enter a container or conduit.

**LENS** - A carefully ground or molded piece of glass, plastic, or other transparent material with opposite surfaces either or both of which are curved by means of which light rays are refracted so that they converge or diverge to form an image.

**LEVERAGE** - The action of a lever. The mechanical advantage of a lever.

**LINKAGE** - A system of interconnected machine parts, as rods, springs, and pivots, for transmitting power or motion.

**LOOSE** - looseness - Not tight fitting, not bound, stapled, bundled or gathered together.

**MALADJUSTMENT** - Faulty adjustment as in a machine.

**MECHANISM** - mechanical device and arrangement of machine parts.

**METALLIC** - Of, relating to or having the characteristics of a metal.

**MINIMUM** - The least possible quantity or degree. The lowest amount or degree reached.

**MIRRORED** - A surface able to reflect enough undiffused light to form a virtual image of an object placed before it.

**MISPLACED** - To put in wrong place.

**MODIFIED** - To change in form or alter. To make less extreme, severe or strong.

**MOTORCYCLE** - means a motor vehicle, other than a tractor, having a saddle for the use of the rider and designed to travel with not more than three wheels in contact with the ground.

**MOVEMENT**- A mechanism that produces or transmits motion.

**MUFFLER** - A device that absorbs esp. one used with an internal combustion engine.

**OBSCURED** - Deficient in light, dark. Lacking a clear delineation, indistinct.

**OEM** - Original Equipment Manufacturer.

**PASSENGER VEHICLE / LIGHT TRUCK** Covers vehicles up to 26,000 lbs.

**PAWL** - A hinged or pivoted device adapted to fit into a notch of a ratchet wheel to impart forward motion or prevent backward motion.

**PERIPHERY** - The outermost region or part within a precise boundary.

**PIT**, pitted - A natural depression or small indentation on a surface. To make cavities, depressions or scars.

**PLEXIGLAS** - A trademark for a light, transparent, weather-resistant thermoplastic.

**PRESSURE** - An application of continuous force by one body on another that it touches.

**PROTRUDE** - To push or thrust outward, to jut out.

**PUMP**, pumping - A device or machine for transferring a gas or liquid from a source or container through tubes or pipes to another container or receive

**RATCHET** - A mechanism consisting of a pawl that engages the sloping teeth of a bar, or wheel, of a ratchet.

**RATING** - To specify performance limits.

**REFLECT** - To throw or bend back light.

**RE-INSPECTION** means an inspection of previously rejected items that is completed within fifteen days of the original inspection.

**REJECT** - To deny a vehicle to pass an inspection with safety items that fail to function properly.

**RESERVOIR** - A receptacle for storing a fluid.

**RESTRICT**, restricted - To hold within limits, to confine.

**RIM** - The circular outer part of a wheel, furthest from the axle. A circular metal structure around which a wheel tire is fitted.

**RIVET** - A metal bolt or pin having a head on one end, used to fasten metal plates or other objects together by inserting the shank through a hole in each piece and hammering down the plain end so as to form a new head.

**ROTOR** - A rotating part of an electrical or mechanical part.

**RUB/rubbing** - To subject to the action of something that moves back and forth with friction and pressure.

**SAGGING** - To lose strength, firmness, or resilience.

**SEAL/SEALED** - An adhesive agent used to close or secure something or prevent seepage of moisture or air.

**SECURE**, secured - Not likely to fail or give way, stable, well-fastened.

**SEEP**, seepage - to pass slowly through small openings or pores. Something that has seeped.

**SEIZE**, seizing - To fuse or cohere with another part due to high pressure or temperature, slowing or stopping further motion.

**SCRATCH**, scratched - To make a narrow line or mark with a sharp instrument. To scrape or strike on an abrasive surface.

**SEVERE** - Corresponding strictly and rigidly to established rule.

**SEVERED** - To become cut or broken apart.

**SHACKLE** - A device used to fasten or couple. (Shackles, something that restrains or confines.)

**SHADE**, shaded - Light reduced in intensity due to interception of the rays; partial darkness. To obscure or to darken.

**SHATTER**, shattered - To cause to break or burst suddenly into pieces. A fragmented or splintered condition.

**SHIMMY** - Abnormal vibration, as in the chassis of a motor vehicle.

**SLIP**, slippage - To move quietly and smoothly, glide. To cause to move in a smooth easy or sliding motion.

**SMEAR** - To stain by or as if by spreading or daubing with a sticky, greasy or dirty substance.

**SNAG** - A sharp rugged or jagged protuberance.

**SPECIFICATIONS** - An exact written description of an item

**SPRINGS** - An elastic device, as coil or wire that regains its original shape after removal of stress.

**STABILITY** - Resistance to sudden change, dislodgement, or overthrow. Reliability, dependability.

**STEEPING** - To direct the course, to maneuver, to guide a vessel or vehicle.

**STRUT** - To brace with a supporting bar or rod.

**SUSPENSION** - The system of springs that

protects the chassis of a motor vehicle from shocks transmitted through the wheels.  
PLT Safety Inspection Manual, Effective January 1, 2011 85

**SWITCH** - A device for breaking or opening an electrical circuit or for diverting current from one conductor to another.

**SYSTEM** - A group of interacting mechanical or electrical components.

**TENSION** - A force tending to stretch or elongate something, the measure of such force.

**TILT** - To cause to slope as by raising one end.

**TINT**, tinting - A shade of a color, a slight coloration, a shaded effect. To give a tint or take on a tint.

**TORSION BAR** - A part of an automotive suspension consisting of a bar that twists to maintain stability

**TRACK** - To keep a constant distance apart. Used as a pair of wheels. To be in alignment.

**TRANSMISSION** - An automotive assembly of gears and associated parts by which power is transmitted from the engine to a drive shaft.

**TRAVEL** - To move from one place to another.

**TREAD** - The grooved face of a tire.

**U-BOLT** - A bolt shaped like the letter "U", fitted with threads and a nut at each end.

**UNLADEN** - Without load.

**USDOT** - United States Department of Transportation.

**VACUUM** - A state of being sealed off from external or environmental influences.

**VALVES** - A device that regulates the flow of gases, fluids or loose materials through a pipe, the moveable control element.

**VERTICAL** - Being at right angles to the horizon.

**VINTAGE VEHICLE** - means a motor vehicle that is 40 years old or older, from the current year, primarily a collector's item, and used for participation in club activities, exhibitions, tours, parades, occasional transportation, and similar uses, but that is not used for general daily transportation.

**VISUAL** - Capable of being seen by the eye.

**WEEPING** - To ooze, exude, or let fall drops of liquid. Drops of moisture.

**WEIGHT** - A measure of the heaviness or mass of an object.

**WELDED** - To join metals by applying heat, sometimes with pressure and sometimes with an intermediate or filler metal having a high melting point.

**WIDTH** - The measurement of the extent of something from side to side.

**WORN** - Affected by use or wear, impaired, damaged, or showing fatigue by use or wear.